

# Coatema Click&Coat™



click +



click +



click ...

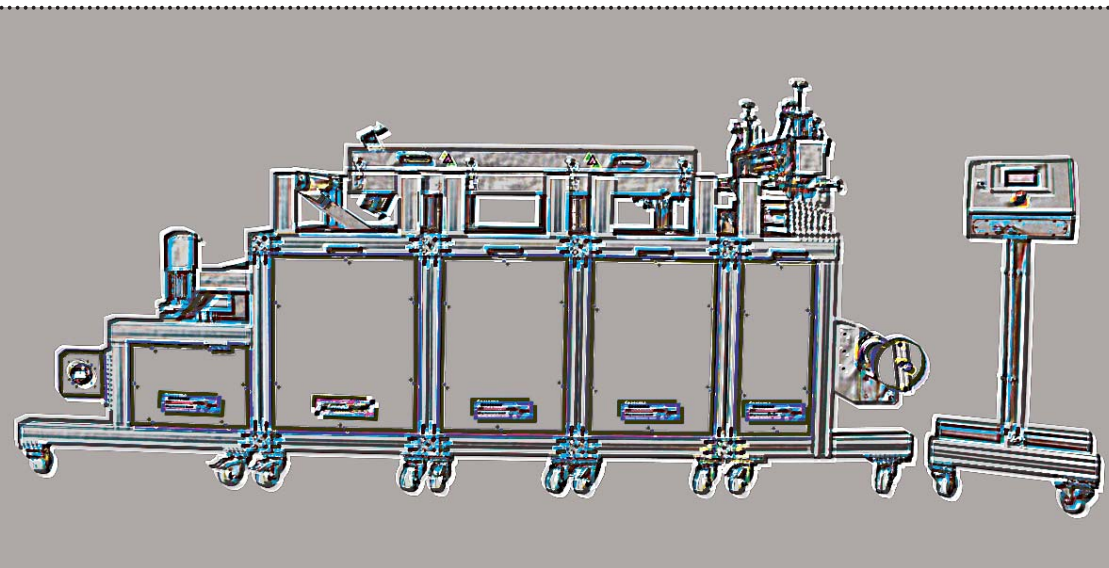
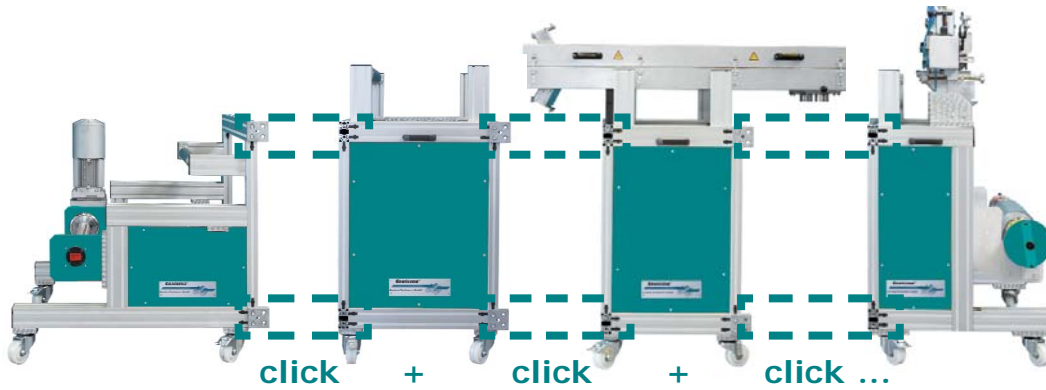

## Benefits:

- ✓ The Click&Coat™ pilot coater is primarily intended to be used for forcing up the efficiency of processes and for a further development of coating and laminating technology
- ✓ So far more than 25 standard units available
- ✓ Increasing production speed at any time, capacity to easily scale up
- ✓ New units can be constructed and integrated any time
- ✓ At all time full flexibility for user
- ✓ Click&Coat™ means unlimited possibilities, create the machinery you need right now!

Visit us on the ICE exhibition  
March 27-29, 2007 in Munich,  
Germany!



booth 2 - K 21

# Coatema Click&Coat™

New and emerging technologies like flexible solar cells, fuel cells, advanced batteries and nano materials have driven the development of new coating and laminating approaches over the last decade.

Early on Coatema Coating Machinery recognized that the right fit of the equipment is vital to minimize the expenses of chemistries and substrates as well as labour and work-space. We have always designed our machines with the built-in capacity to scale-up, change-out or replace components as required by process or business developments.

Building on their modular coating head expertise Coatema has introduced an innovative Click&Coat™ concept for pilot coating lines. With Click&Coat™ not only the coating heads are changeable but the whole pilot-line itself is totally flexible. This means most components can be moved, "clicked" into place, and simply plugged to the new invented electrical control system.

A new Coatema Click&Coat™ pilot coater can be assembled from a selection of over twenty modules that can be combined in a variety of configurations to deliver a pilot-line to

meet the most demanding performance requirements.

When tasks have to be fulfilled, additional modules will be added to the selection so that every Click&Coat™ line can include the latest technology. Custom, one of kind, units can be developed based on very specialized needs for proprietary applications without the need to build an expensive completely customized line.

In addition to the flexibility advantage it is also much easier to enlarge processes, attain

higher production speed or generally upscale your pilot coater by lengthening a coating processes or adding dryer modules for example.

If you are interested in learning more about this concept you can contact Moritz Graf zu Eulenburg at Coatema Coating Machinery GmbH or visit our website at [www.coatema.de](http://www.coatema.de)

## → Survey of modules

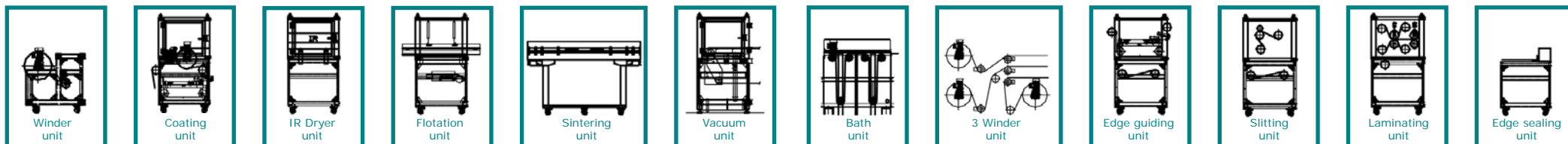

## → View of a possible configuration:

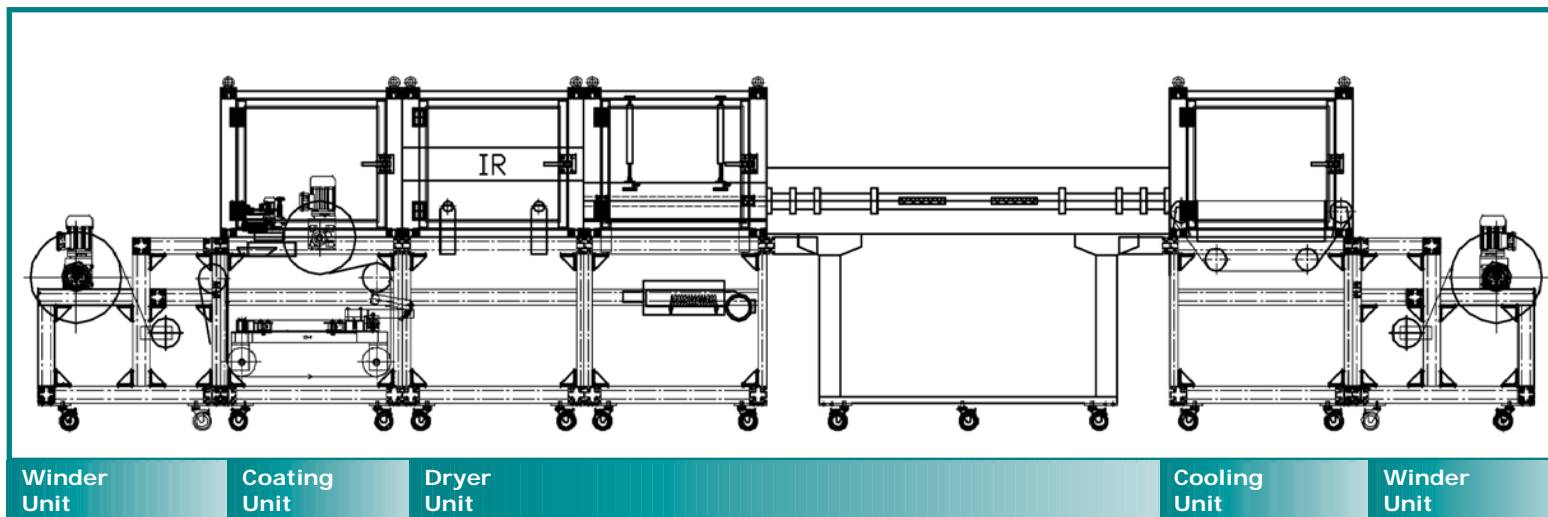

**Coatema**  
Coating Machinery GmbH  
Rosellerstraße 4 - D-41539 Dormagen

Tel.: +49 (0) 21 33 / 97 84 - 0  
Fax: +49 (0) 21 33 / 97 84 - 170  
e-mail: [info@coatema.de](mailto:info@coatema.de)  
Internet: [www.coatema.de](http://www.coatema.de)