

Technology development and manufacturing for fuel cells and electrolyzers

Coatema

11/12/2024

MEMBER OF ATH

Agenda

1. Introduction
2. Today's equipment
3. Coating systems
4. Slot die for fuel cells
5. Digital application system
6. Drying technologies
7. Simulation
8. Summary



1.

Introduction

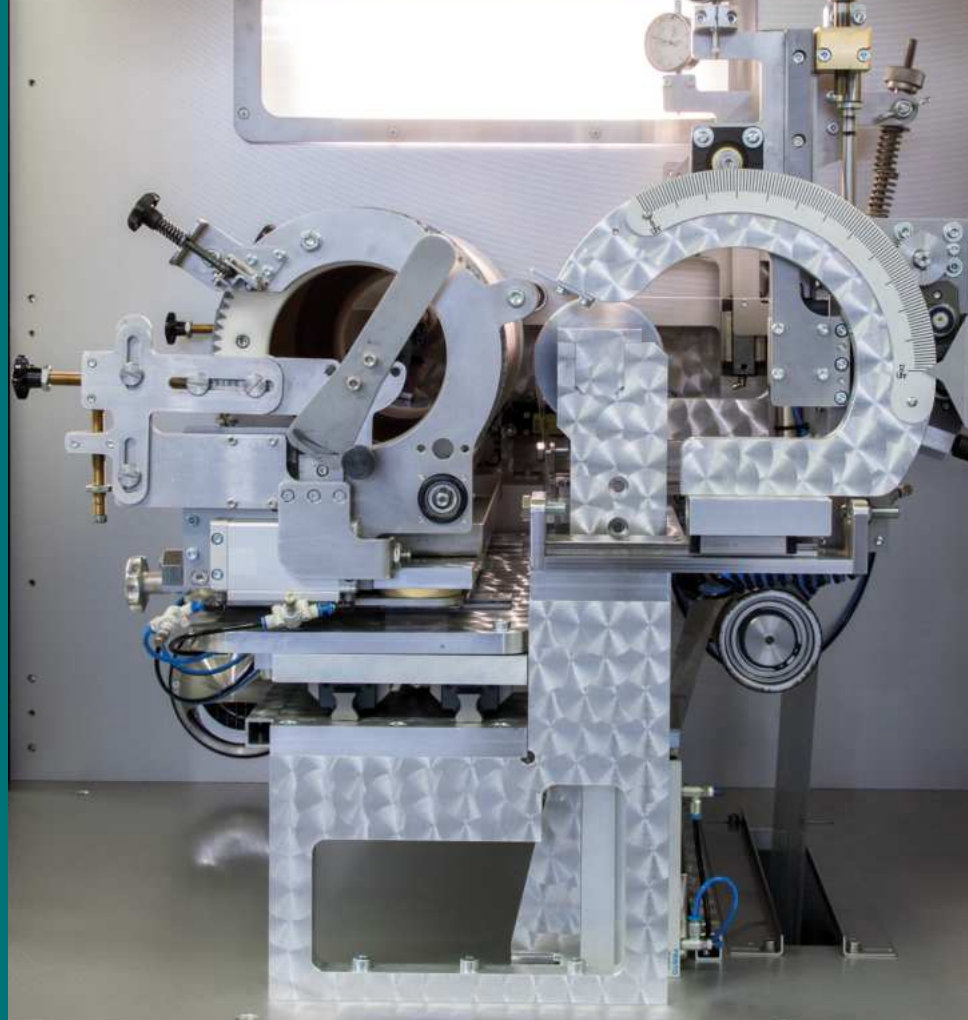

Overview

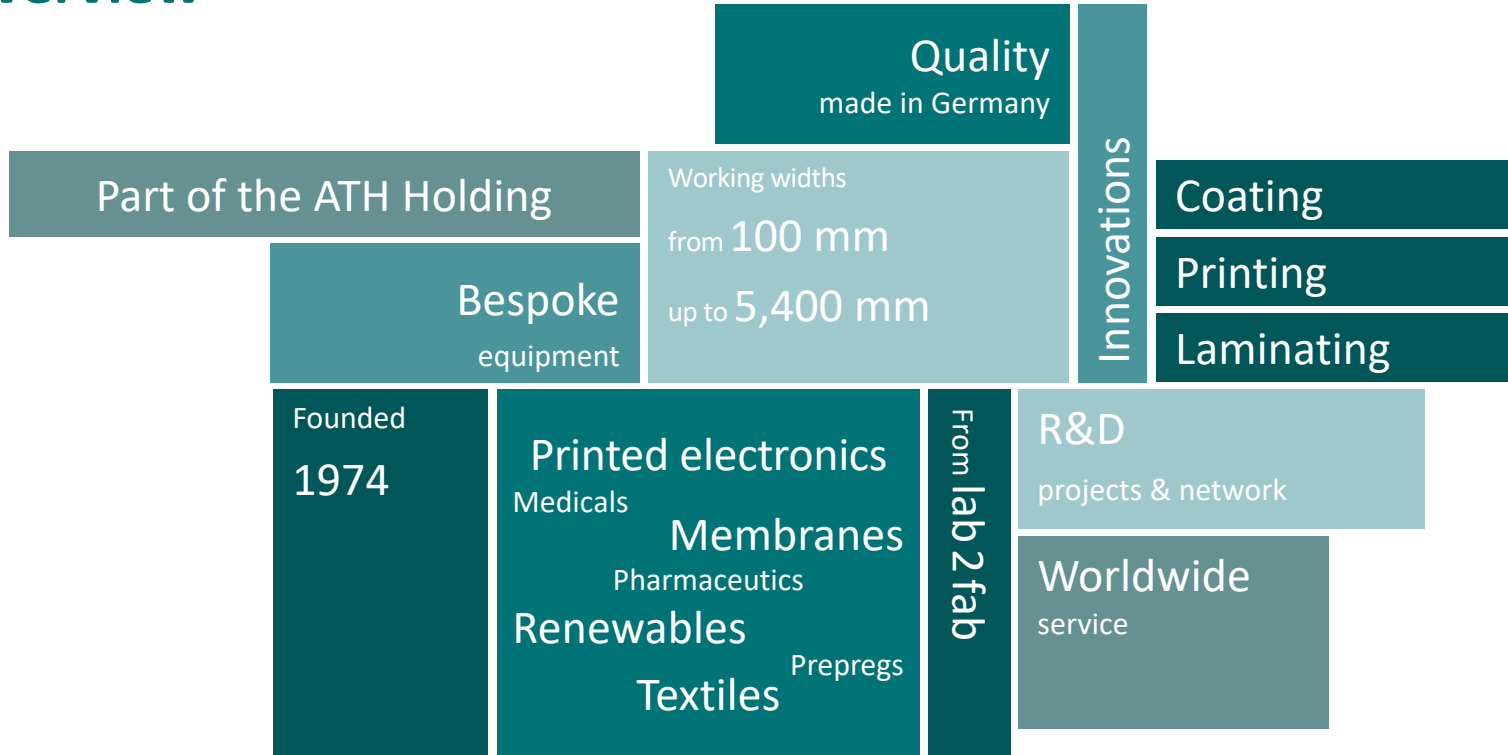

Group of companies

ATH ALTONAER
TECHNOLOGIE
HOLDING



KROENERT

- ✓ Founded 1903
- ✓ Approx. 200 employees
- ✓ Located in Hamburg

DRYTEC

- ✓ Founded 1995
- ✓ Approx. 50 employees
- ✓ Located in Norderstedt



Coatema[®]
Coating Machinery GmbH

- ✓ Founded 1974
- ✓ Approx. 50 employees
- ✓ Located in Dormagen

Our markets – Coatema focus areas

Green Hydrogen

Fuel cells

Batteries

Solar



Sustainability

Digital fabrication

Printed
electronics

The next thing

Coatema equipment platform strategy for lab2fab



Lab

- ✓ State-of-the-art research and development equipment
- ✓ Sheet-to-sheet to roll-to-roll systems



Pilot Production

- ✓ Proven electrolyzer and fuel cell coating and laminating equipment
- ✓ Highest-quality pilot product lines enable stable pilot production and reduce cost
- ✓ Scaling laboratory equipment to enable pilot production



Production

- ✓ Full-scale production line for electrolyzers
- ✓ Elevating our in-depth roll-to-roll equipment to fully scale production and further reduce adoption cost

R&D centre USP



Process development

- ✓ Feasibility study
- ✓ Ink – process study
- ✓ Process analysis
- ✓ Slot die coating simulations
- ✓ Proof of concept
- ✓ Small scale prototype



Test production

- ✓ Prototyping
- ✓ Near to market testing
- ✓ TRL evaluation
- ✓ Training of staff



Education

- ✓ Coating conference
- ✓ Partner trainings
- ✓ Education of students
- ✓ Workforce training



Development of custom-made design for equipment

- ✓ Prototyping
- ✓ Proof of concept



Public funded research projects know-how

- ✓ German funded
- ✓ Horizon 2020
- ✓ Global 2+2 projects
- ✓ B2B projects

R&D customers



R&D projects overview 2022 – 2024

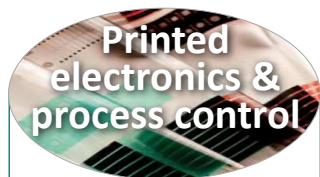

In-line and real-time digital nano-characterization for flexible organic electronics

NOUVEAU PROJECT

The NOUVEAU project will develop solid oxide cells (SOCs) with innovative La- and PMG-free electrode materials

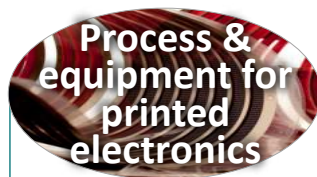

R2R production line for OPV solar with integrated backend



Development of near-field electro hydrodynamic nanowire printing



Implementation of laser drying processes for lithium-ion battery production



R2R process optimization for solid state batteries



Plasmonically enhanced photocatalysis for wastewater treatment

RetroWin

R2R Process and machinery development for retrofit window films for lower production costs



The WaterProof project aims at developing an electrochemical process that converts CO₂ emission



Creating an open-innovation testbed for sustainable packaging

2.

Today's equipment for
today's
fuel cells/electrolyzers

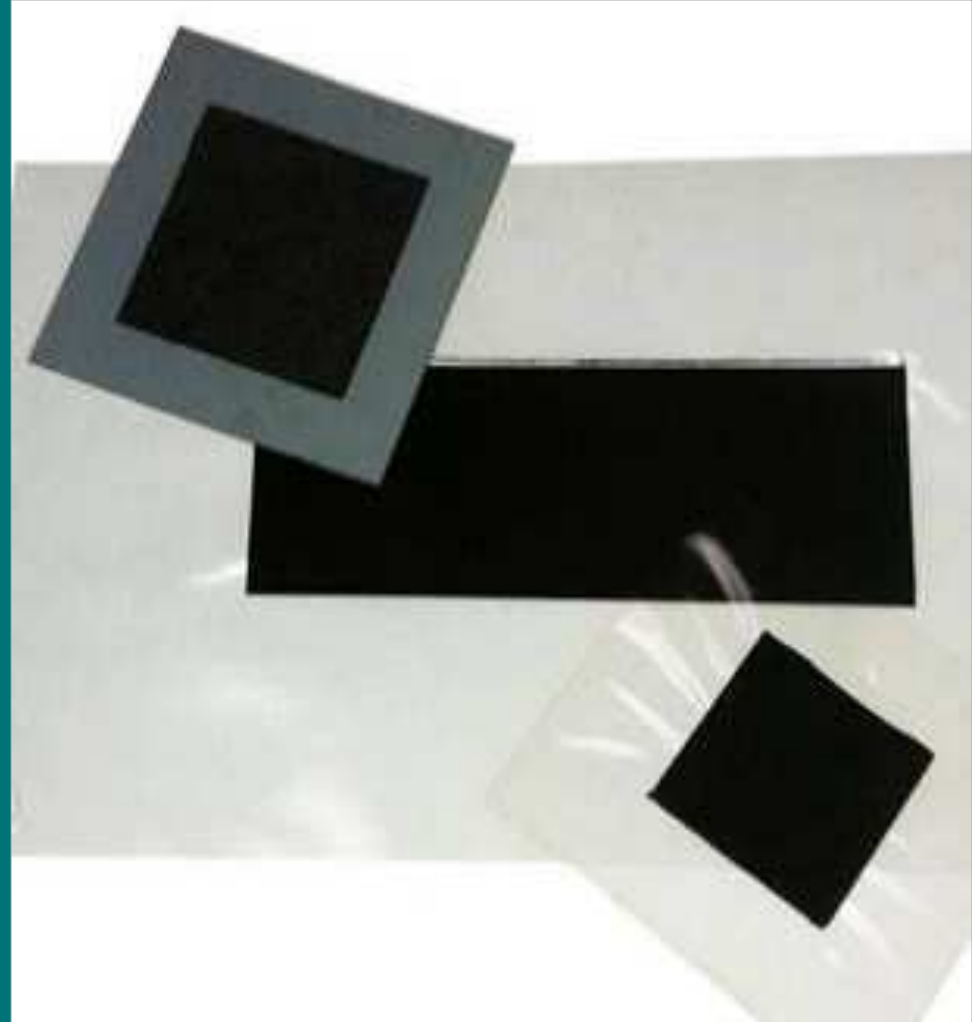

Reference equipment for electrolyzer Coatema

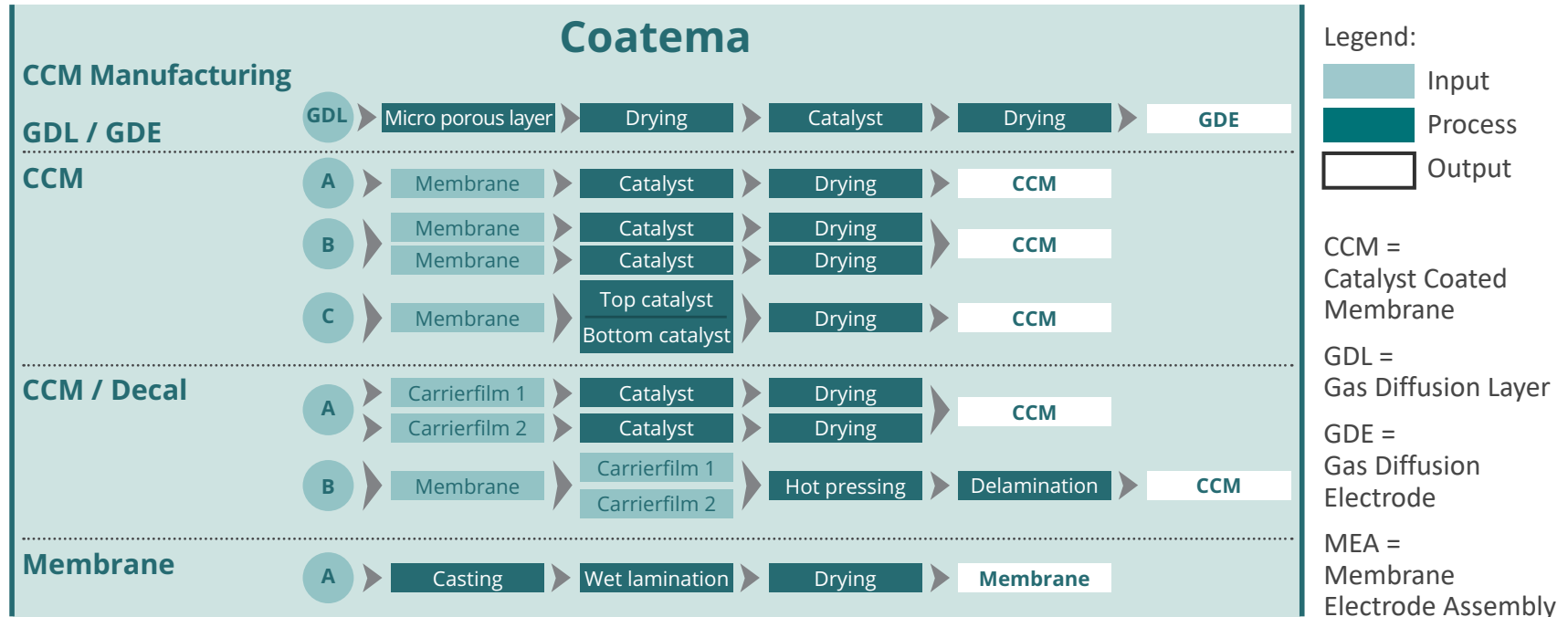

S2S



Test Solution

Ink testing



Easycoater

First sample product



Easycoater Evolution

First pilot as S2S

Today's equipment

Roll-to-Roll (R2R) lab systems

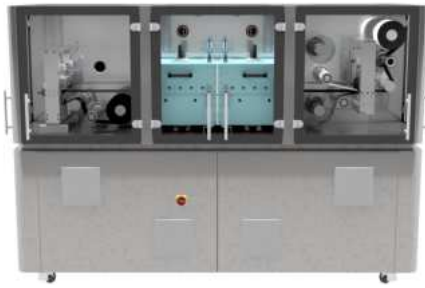

Test Solution R2R

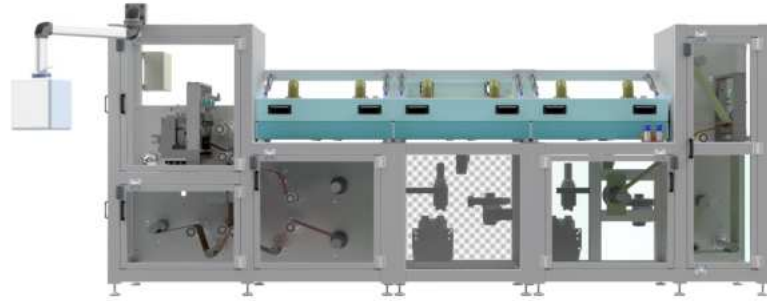

Basecoater R2R



Smartcoater R2R

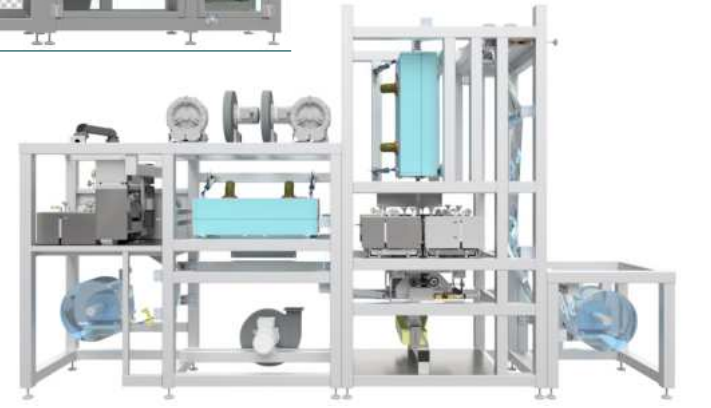

Verticoater R2R

Today's equipment for batteries

The Smartcoater



Today's equipment for batteries

The Smartcoater



Today's equipment

Roll-to-Roll (R2R) pilot



Basecoater Pilot R2R

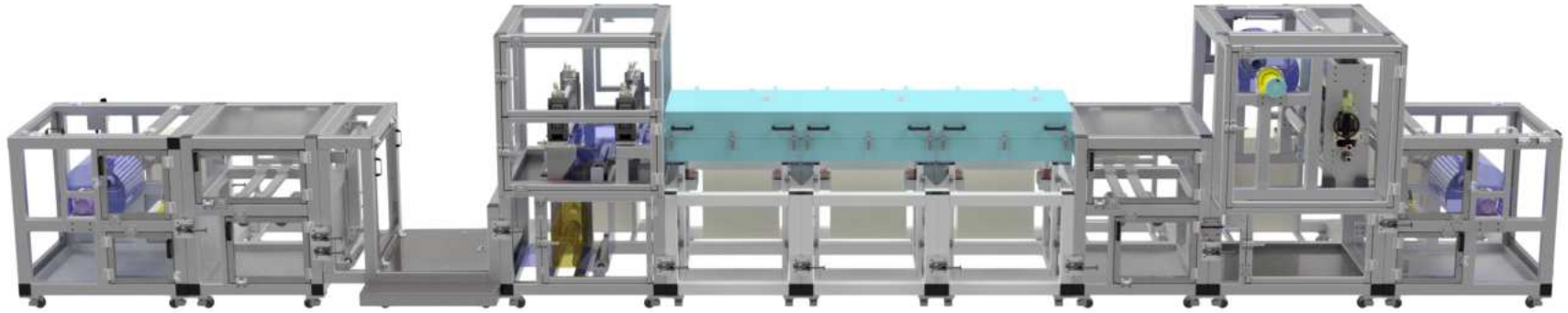

Click&Coat™ R2R

Today's equipment

The Click&Coat™

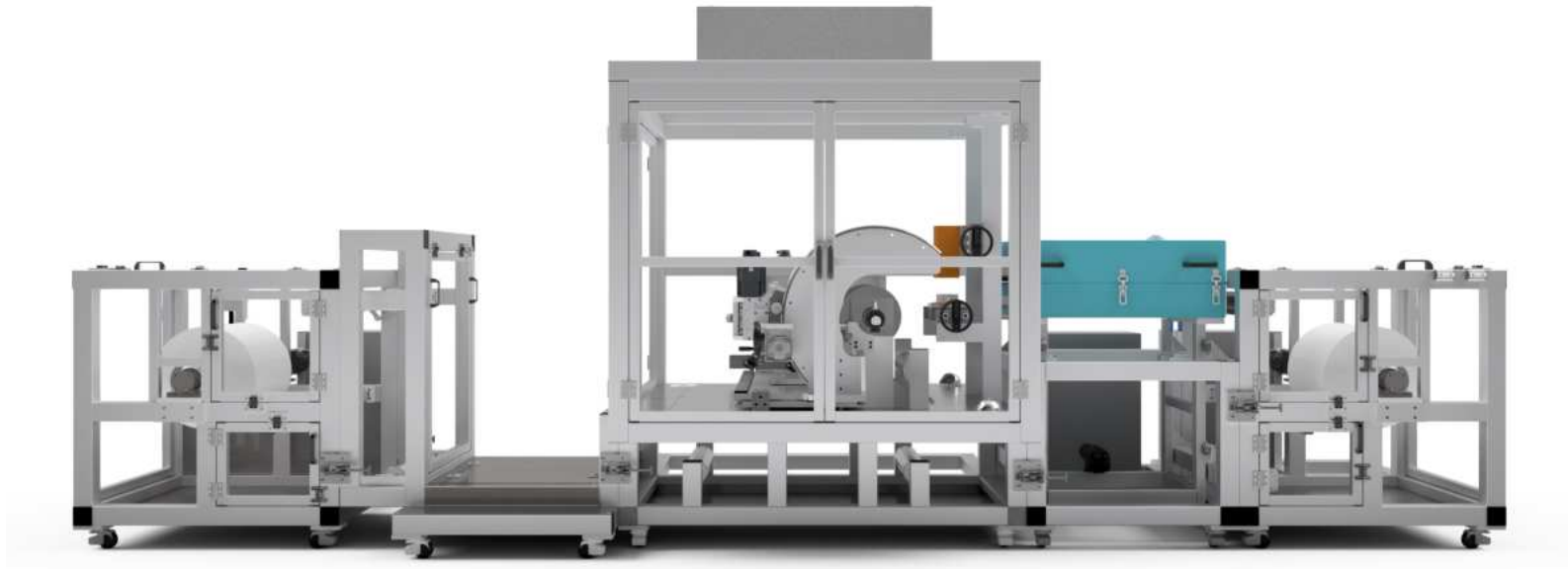

Today's equipment

The Click&Coat™

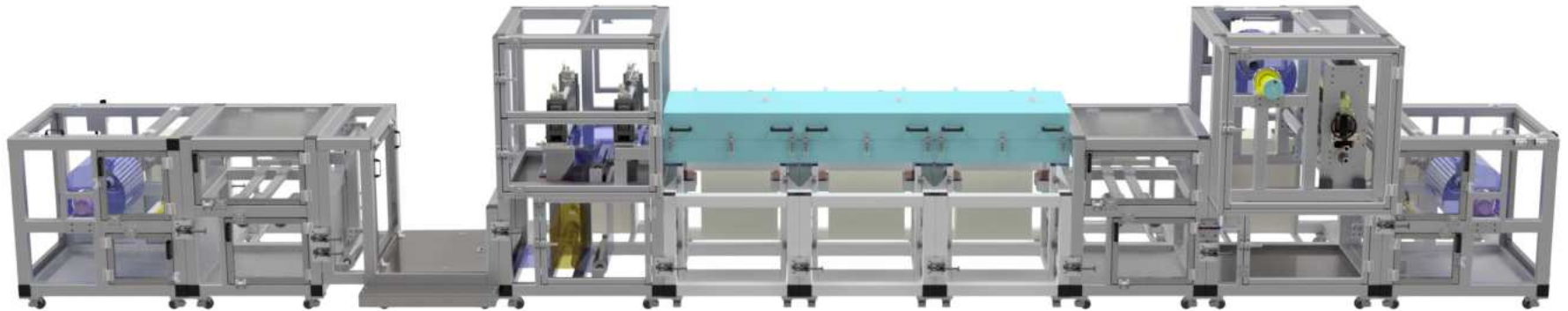

GDE and CCM coating lines

GDE method

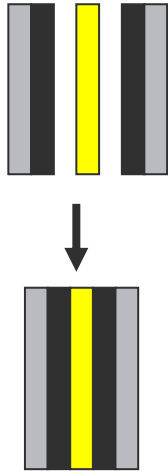

CCM direct

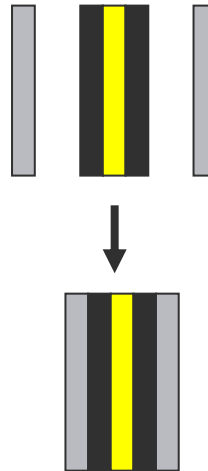

Today's equipment

The Click&Coat™



Today's equipment

The Click&Coat™



Today's equipment

Specific equipment in Click&Coat™ layout



Click&Coat™ your own ideas



Winder

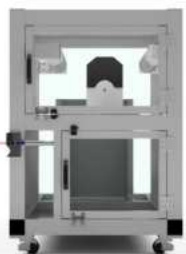

Corona



Podestral



Coating



Printing



Dryer



Laminator



Rewinder



Chemical treatment bath



Inert Coating and laminating



Registration control



Turning device

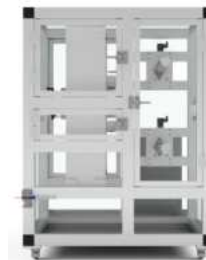

Lamination



Cutting

Today's equipment

The Click&Coat™ in production scale in the R&D centre

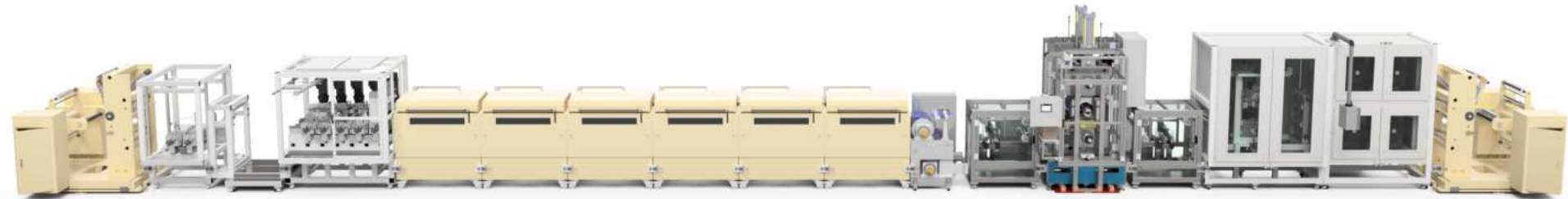

Today's equipment

The Click&Coat™ in production scale



Today's equipment

The Click&Coat™ in production scale

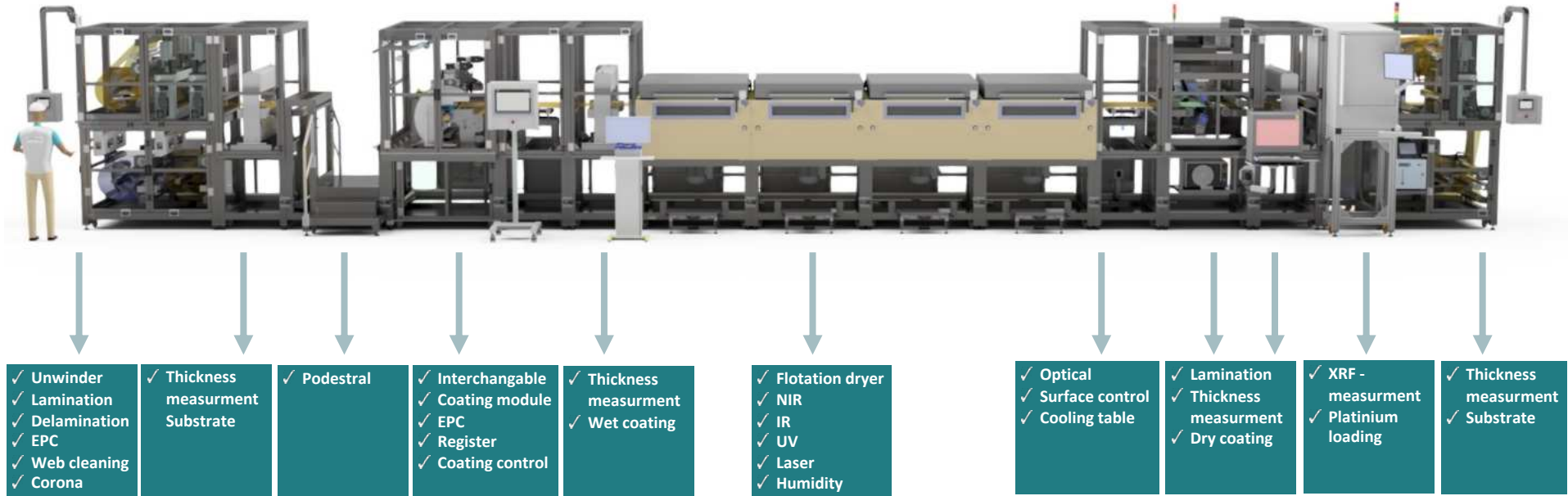

Today's equipment

The Click&Coat™ in production scale



Today's equipment

The Click&Coat™ in production scale



Indirect CCM (Decal) Method

CCM indirect

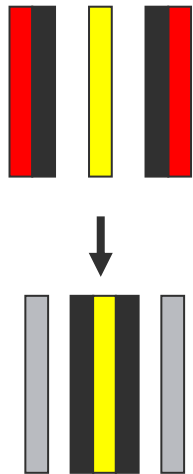

Today's equipment for fuel cells

Hot pressing



Today's equipment for fuel cells

Decal 3rd Generation

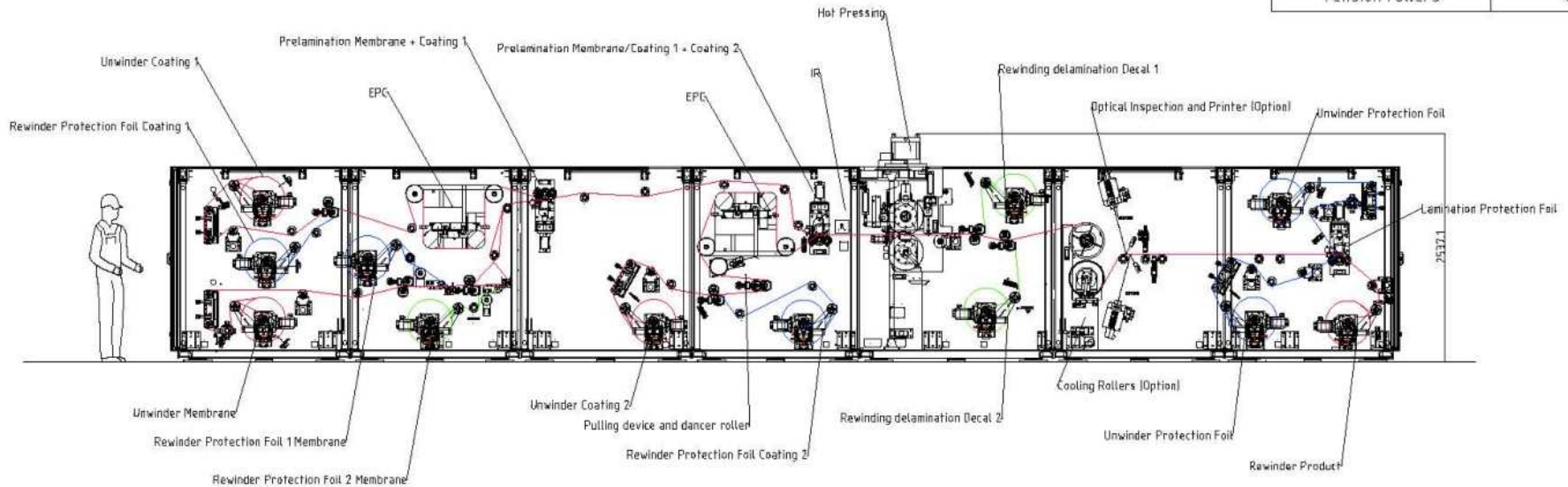

Membrane casting and reinforced membrane (wet lamination)

**Membrane
(Casting)**



**Reinforced
Membrane
(wet lamination)**



Today's equipment for fuel cells

Membrane casting



Today's equipment for fuel cells

Membrane casting

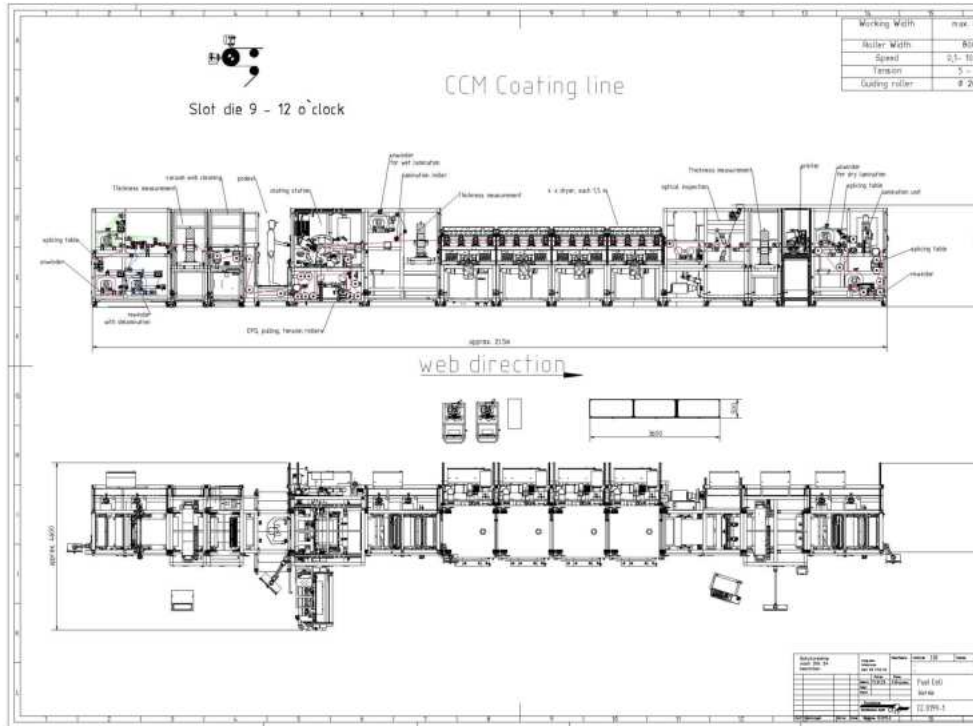

Production line for fuel cells – 1000 mm working width



3.

Coating systems



Coating parameters

Coating chemistry	Coating processes	Process control	Drying
<ul style="list-style-type: none"> ✓ Rheology ✓ Viscosity ✓ Viscoelasticity ✓ Type of solvents ✓ Solid content ✓ Van der Waals force ✓ Sheer ratio ✓ Adhesion/Cohesion 	<ul style="list-style-type: none"> ✓ Coating systems ✓ Single or multilayer coatings ✓ Direct coatings ✓ Transfer (indirect) coatings ✓ Substrate speed ✓ Layer thickness ✓ Coating accuracy 	<ul style="list-style-type: none"> ✓ Process layout ✓ Tension control system ✓ Material guiding system ✓ Inline parameter control ✓ Quality control 	<ul style="list-style-type: none"> ✓ Convection drying ✓ Contact drying ✓ Infrared drying ✓ Sintering ✓ NIR ✓ High frequency ✓ UV crosslinking systems
Substrate	Pretreatment	Environment	Finishing
<ul style="list-style-type: none"> ✓ Surface tension ✓ Dimension stability ✓ Surface structure ✓ Contact angle 	<ul style="list-style-type: none"> ✓ Corona ✓ Plasma ✓ Cleaning 	<ul style="list-style-type: none"> ✓ Humidity ✓ Temperature ✓ Inert conditions 	<ul style="list-style-type: none"> ✓ Calendaring ✓ Embossing ✓ Slitting

Printing systems

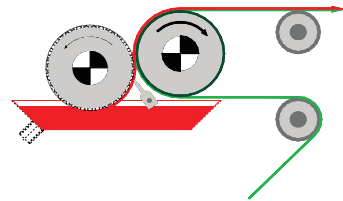

Engraved roller system

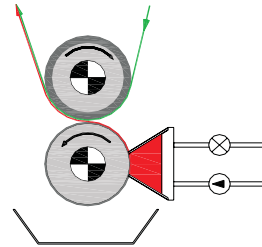

Gravure roller system

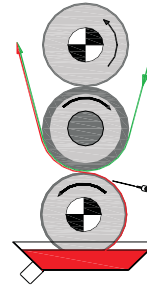

Gravure indirect system

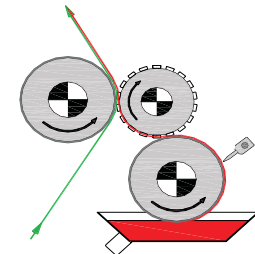

Flexography system

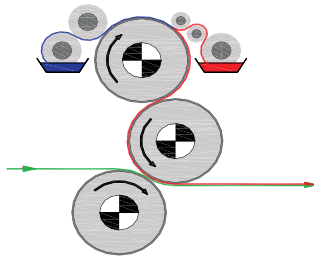

Offset lithography system

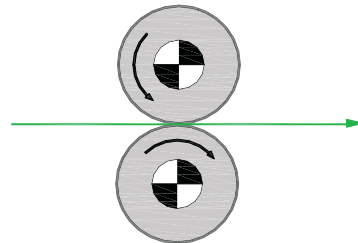

Hot embossing system

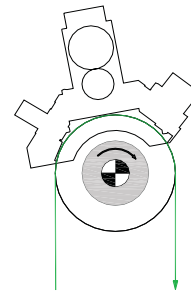

Nanoimprint system

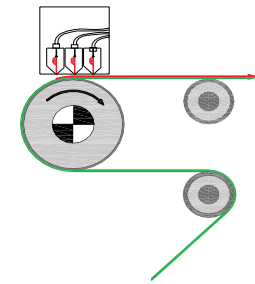

Inkjet system

Knife coating

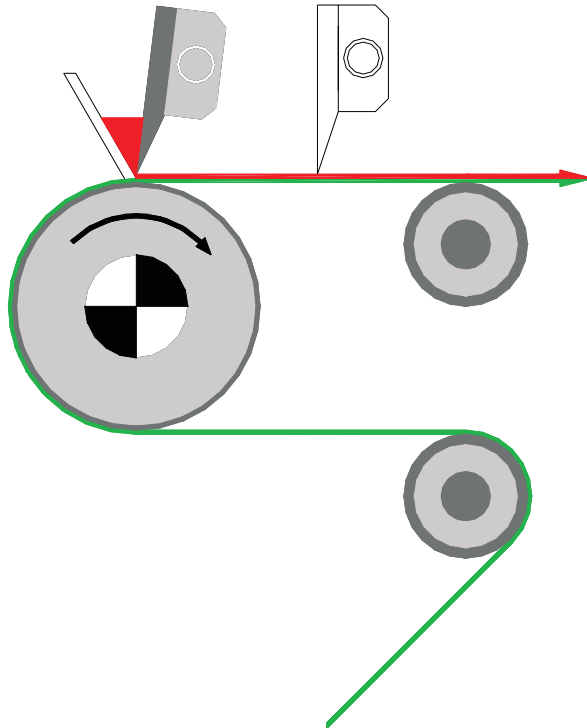

Variation of the coating weight

- ✓ Roller knife
10 – 1.250 g/m²
- ✓ Air knife 5 – 6 to 60 g/m²

Range of viscosity

- ✓ Paste (1000)
100 – 50 000 mPas
- ✓ Foam
10 000 – 25 000 mPas
- ✓ Air knife
5 – 10 000 mPas

Commabar coating

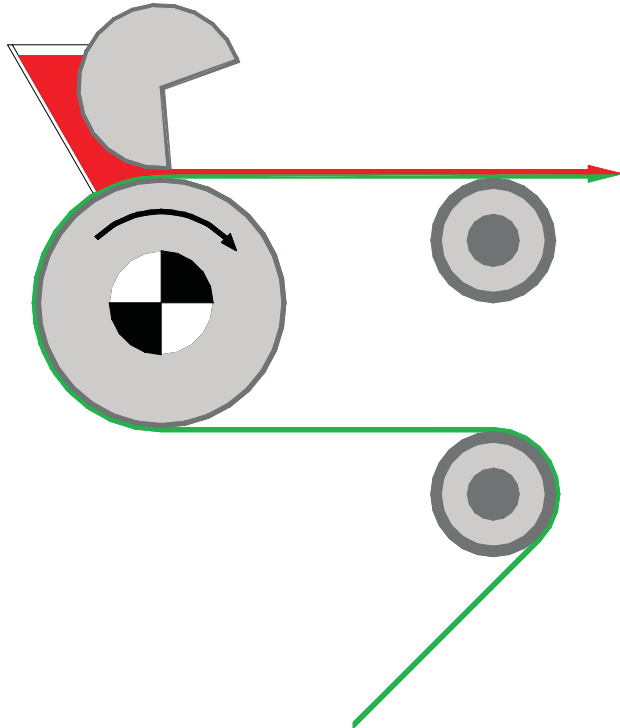

Variation of the coating weight

- ✓ Air knife
5 – 6 to 1.250 g/m²

Range of viscosity

- ✓ Paste
5 – 6 to 60 g/m²
- ✓ Foam
10 000 – 25 000 mPas

Gravur coating

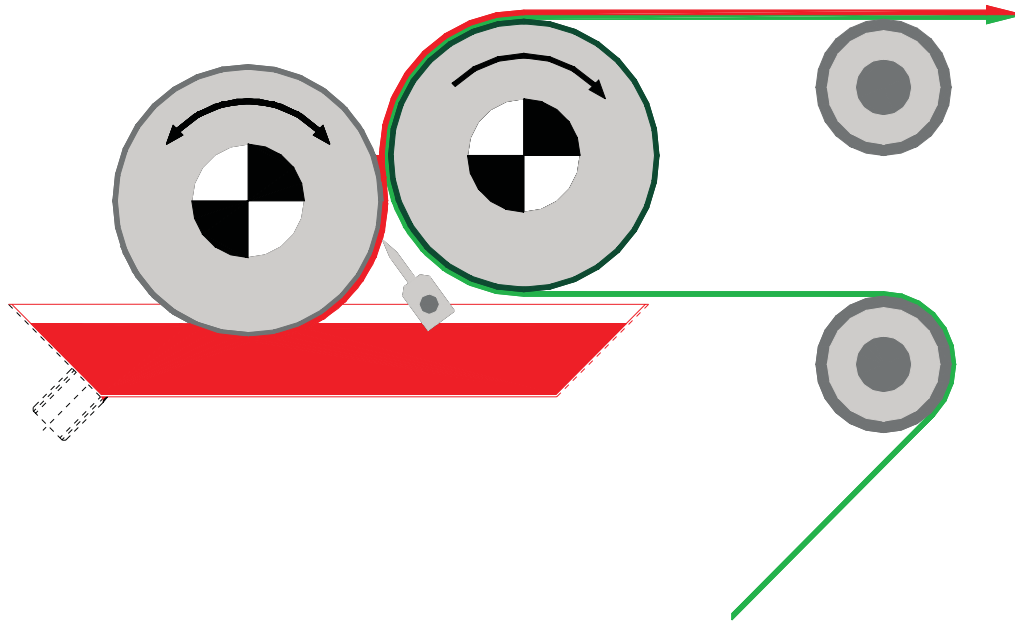

Variation of the coating weight

✓ 2 – 200 g/m²

Range of viscosity

✓ 1 – 15 000 mPas

Rotary screen coating

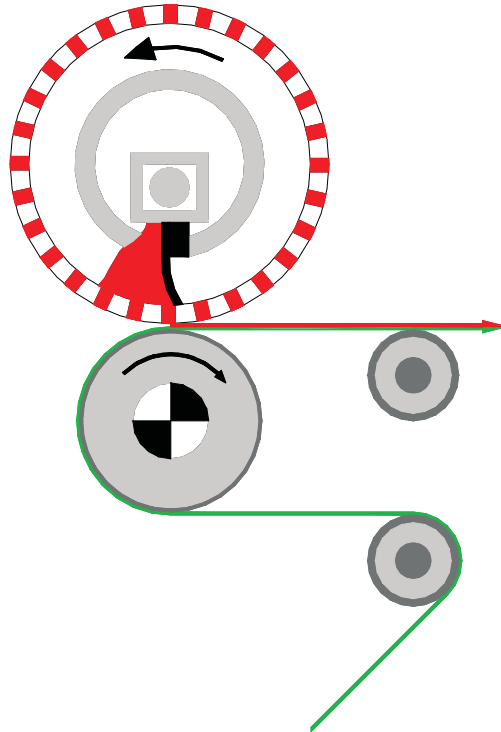

Variation of the coating weight

✓ 10 – 300 g/m²

Range of viscosity

✓ Paste

10 000 – 80 000 mPas

✓ Paste

10 000 – 25 000 mPas

Slot die coating

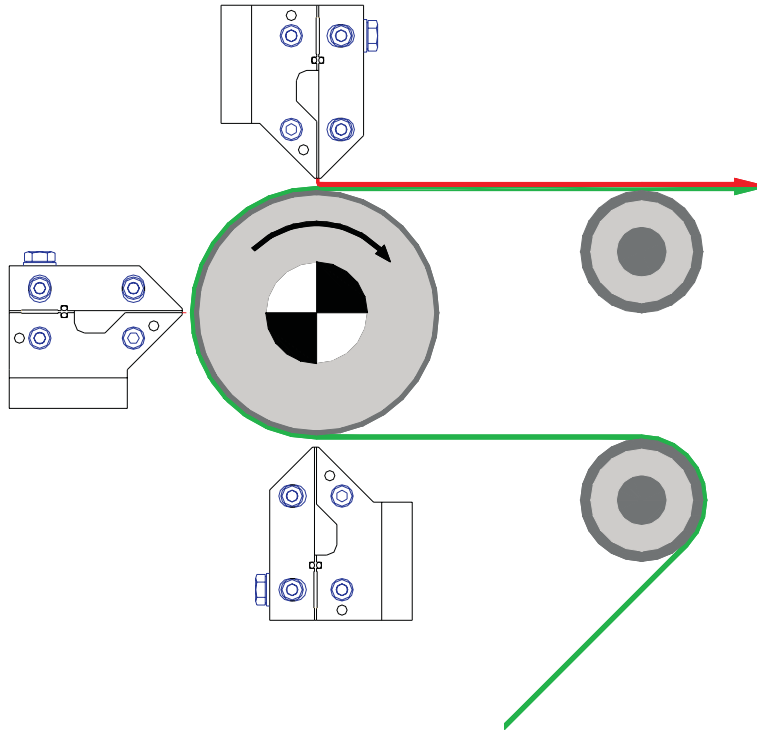

Variation of the coating weight

✓ 1 – 200 g/m²

Range of viscosity

✓ 1 – 30 000 mPas

4.

Slot die coating for fuel cells

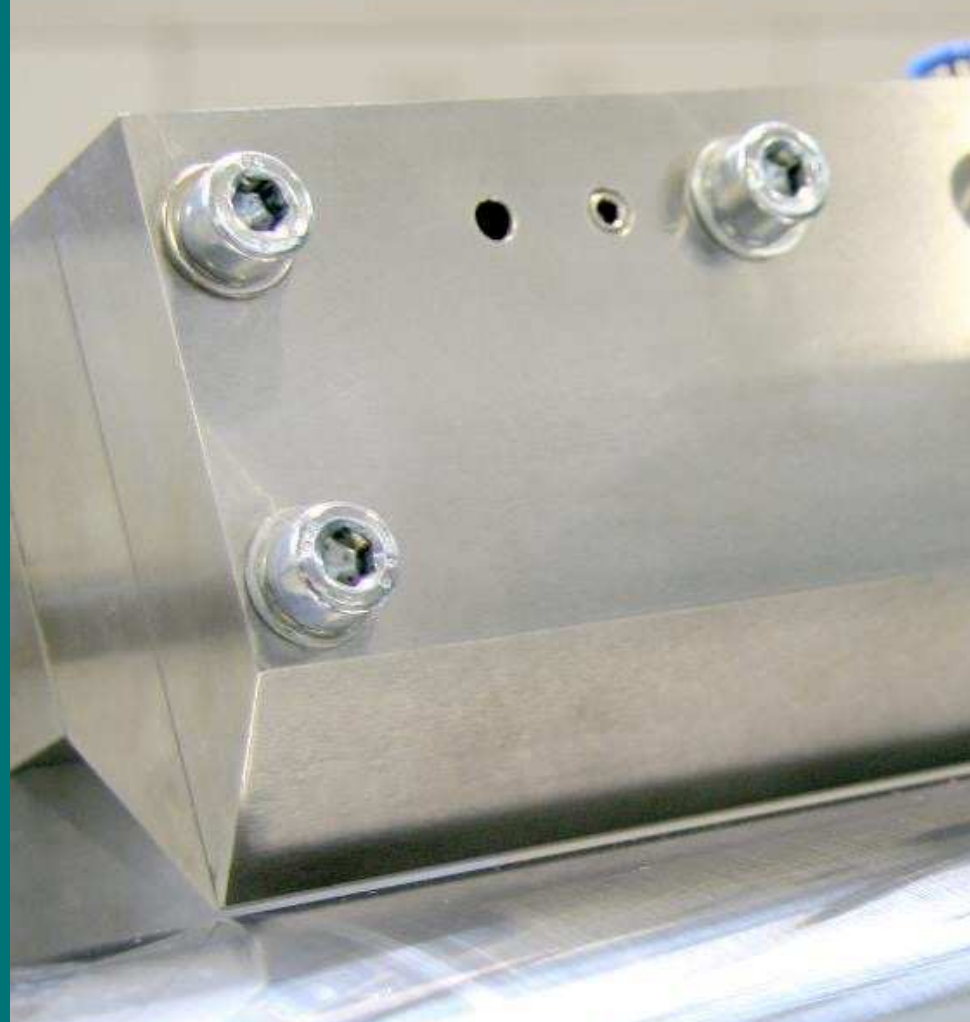

Basic principle



Coating parameters

Ink properties	Coating processes	Process control	Drying
<ul style="list-style-type: none"> ✓ Rheology ✓ Viscosity ✓ Viscoelasticity ✓ Type of solvents ✓ Solid content ✓ Van der Waals force ✓ Sheer ratio ✓ Adhesion/Cohesion 	<ul style="list-style-type: none"> ✓ Coating systems ✓ Single or multilayer coatings ✓ Direct coatings ✓ Transfer (indirect) coatings ✓ Substrate speed ✓ Layer thickness ✓ Coating accuracy 	<ul style="list-style-type: none"> ✓ Process layout ✓ Tension control system ✓ Material guiding system ✓ Inline parameter control ✓ Quality control 	<ul style="list-style-type: none"> ✓ Convection drying ✓ Contact drying ✓ Infrared drying ✓ Sintering ✓ NIR ✓ High frequency ✓ UV crosslinking systems
Substrate	Pretreatment	Environment	Finishing
<ul style="list-style-type: none"> ✓ Surface tension ✓ Dimension stability ✓ Surface structure ✓ Contact angle 	<ul style="list-style-type: none"> ✓ Corona ✓ Plasma ✓ Cleaning 	<ul style="list-style-type: none"> ✓ Humidity ✓ Temperature ✓ Inert conditions 	<ul style="list-style-type: none"> ✓ Calendaring ✓ Embossing ✓ Slitting

Coating systems

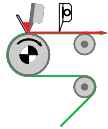

Knife system

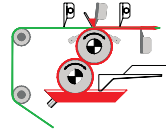

Double side coating system

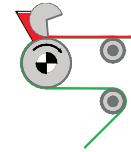

Commabar system

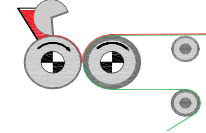

Reverse commabar system

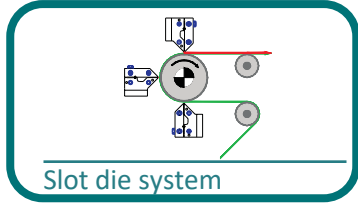

Slot die system

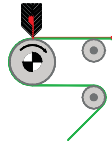

Curtain coating system

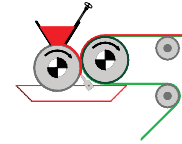

Case knife system

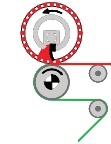

Rotary screen system

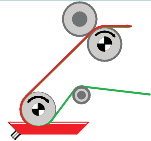

Dipping system (Foulard)

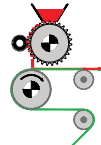

Powder scattering system

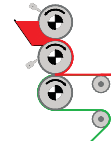

Reverse roll coating system

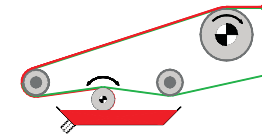

Micro roller coating system

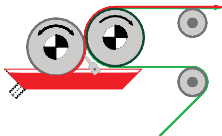

2-roller coating system

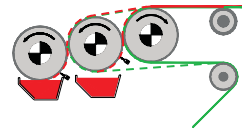

3-roller combi coating system

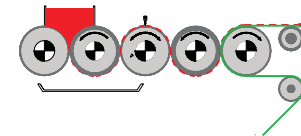

5-roller coating system

Basics of slot die coating – range of parameters

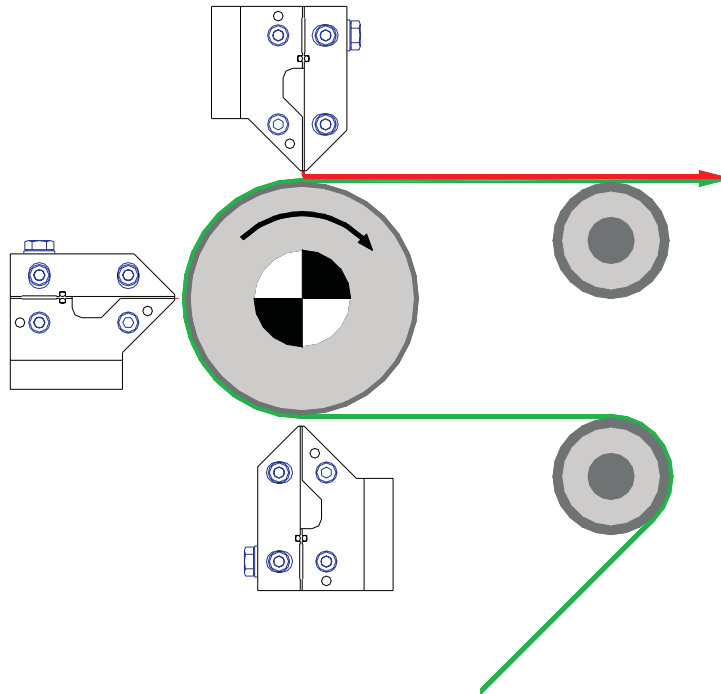

Coating speed

✓ 0.1 – >1000 m/min

Ink viscosity

✓ 1 – 300 000 mPas

Layer thickness (dry)

✓ 0.1 – >200 μm

Coating accuracy

✓ <1% (2 – 5%)

Coating width

✓ up to approx. 3 m

Basic principle

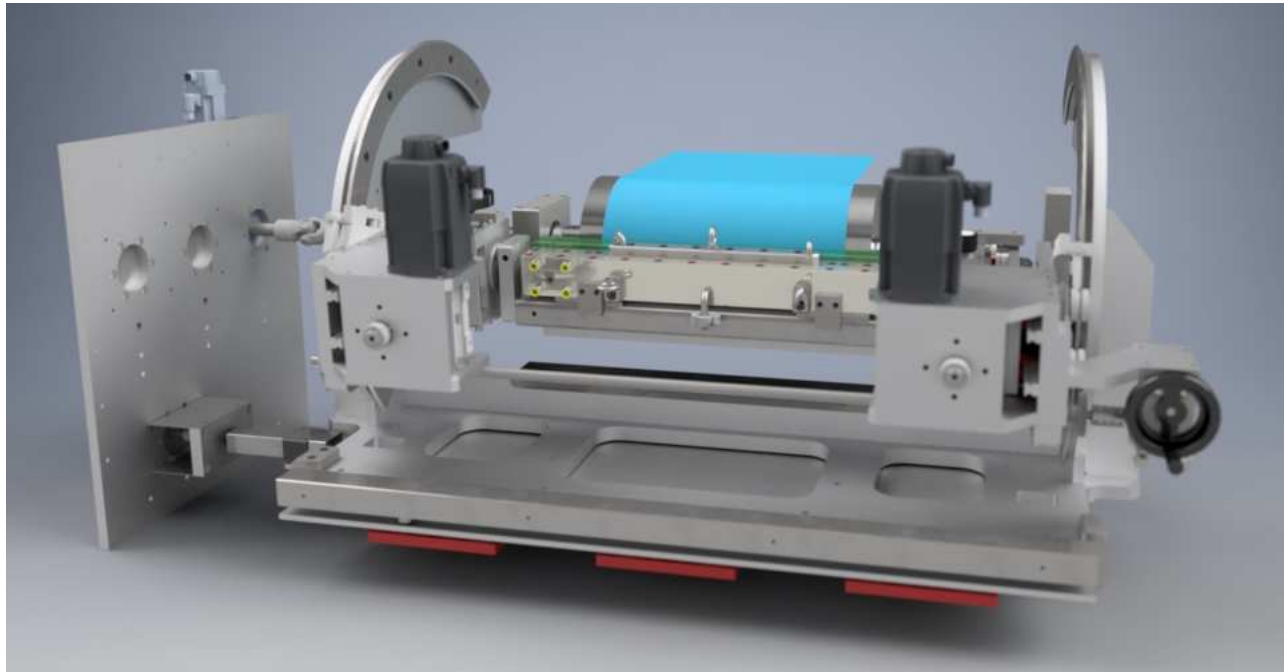

Basic principle



Basic principle

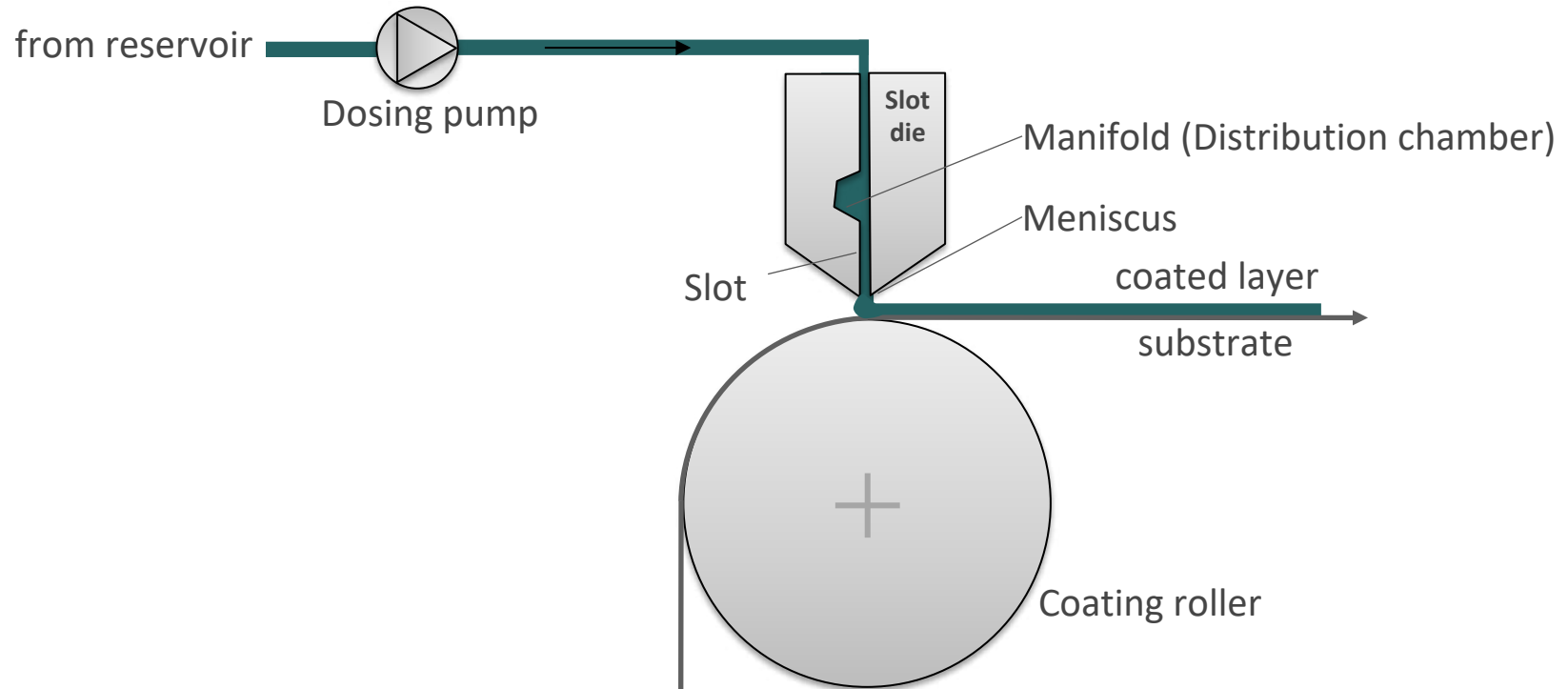

Bead mode

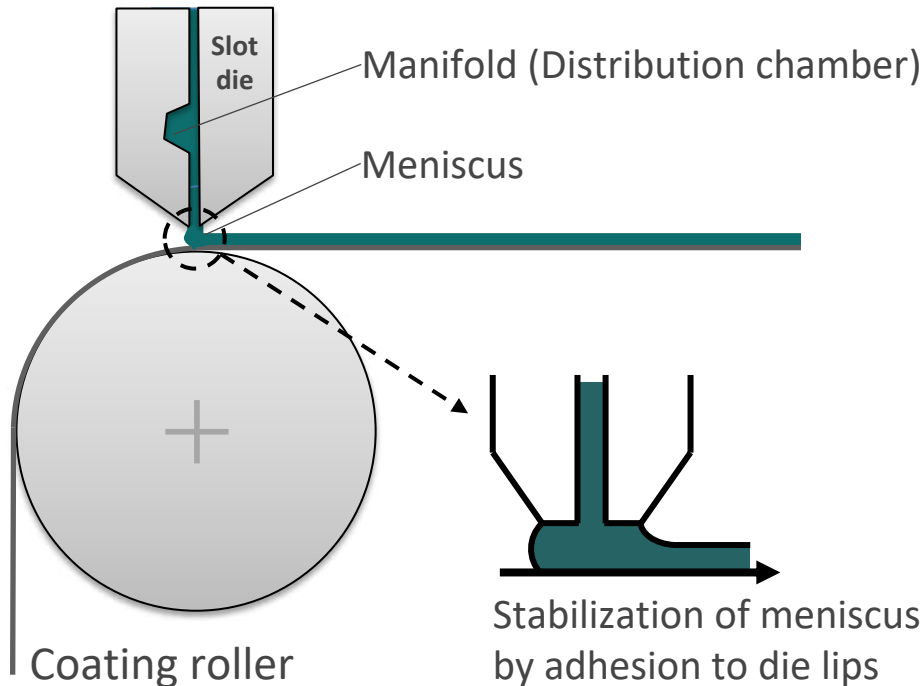

- ✓ Meniscus is formed between die lips and substrate
- ✓ Adhesive stabilization of meniscus by die lips
- ✓ Very low minimum flow rate possible
- ✓ For a stable process the range of rheological parameters is limited
- ✓ Preferably for low coating speed

Theoretical background – „Basic“ fluid dynamics for advances geometries

$$\oint \rho v dA = 0$$

Continuity equation
(conservation of mass)

Any flow of liquids is described by a set of differential equations:

To describe the meniscus flow of a slot die means, to solve these differential equations for given boundary conditions.

Can be done by appropriate computer programs.

$$\frac{\partial v}{\partial t} + (v \nabla) v = \frac{(-\nabla p + \eta \Delta v + f)}{\rho}$$

Navier-Stokes-equations (equations of motion for incompressible fluids, $\rho = \text{const}$)

$\Delta, \nabla =$ differential operators

Calculation of the meniscus stability

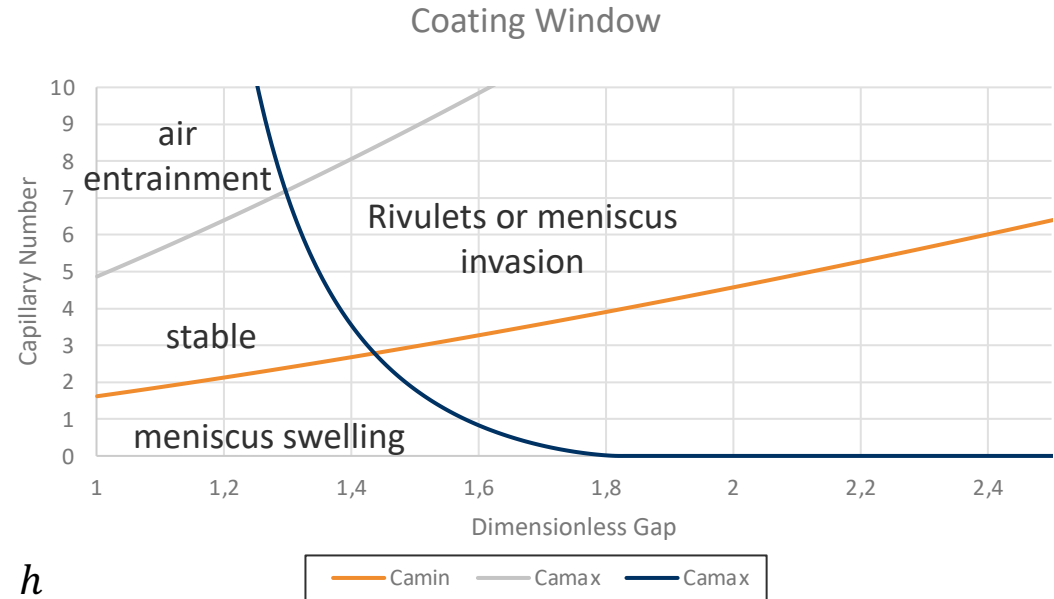
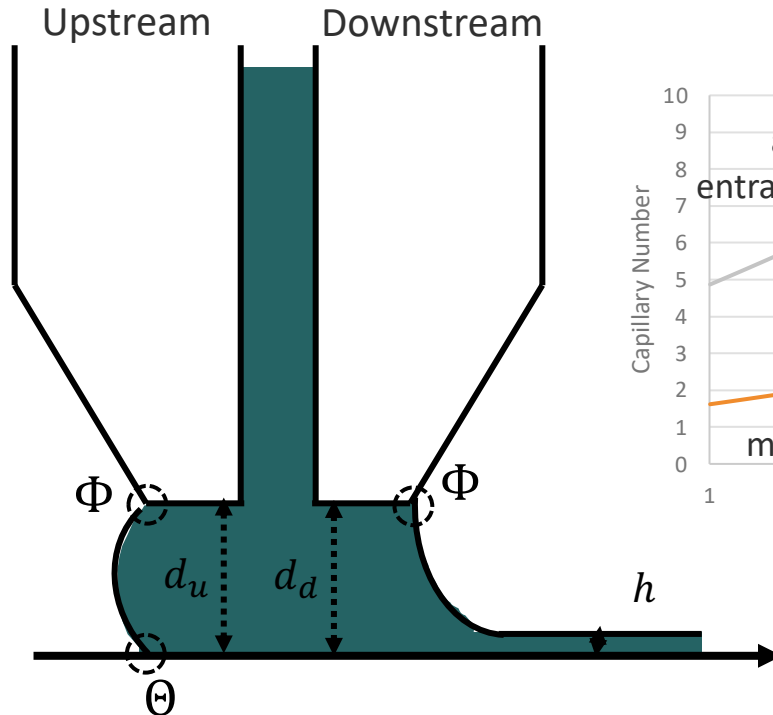

Standard techniques for intermittent coating

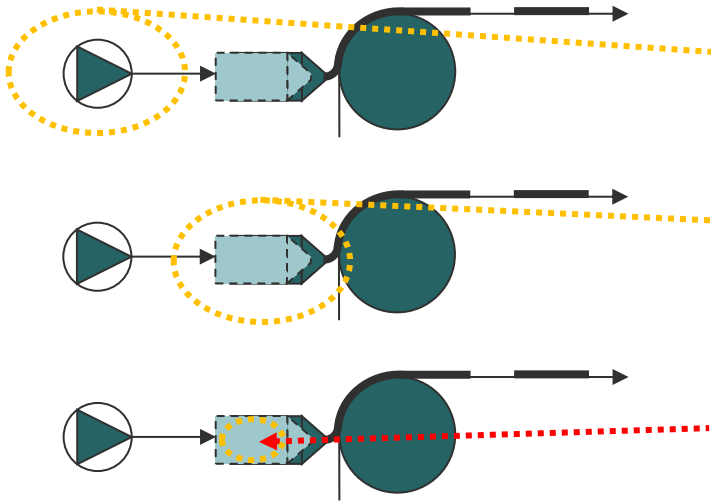

Pump:
stop – reverse – restart

Slot die body:
move back – move forth to minimum gap –
move back to working gap (wedge procedure)

Slot die internal:
stop and redirect the flow by shutters and
valves. Pump flow continues, die flow stops.

All 3 techniques (single or in combination) work quite well, if the viscosity is rather high and the required edge definition is not more precise than around 1 mm. All techniques may be combined with a vacuum pump upstream to stabilize the meniscus and suck away residual liquid.

Structured coating – the switching slot die lip

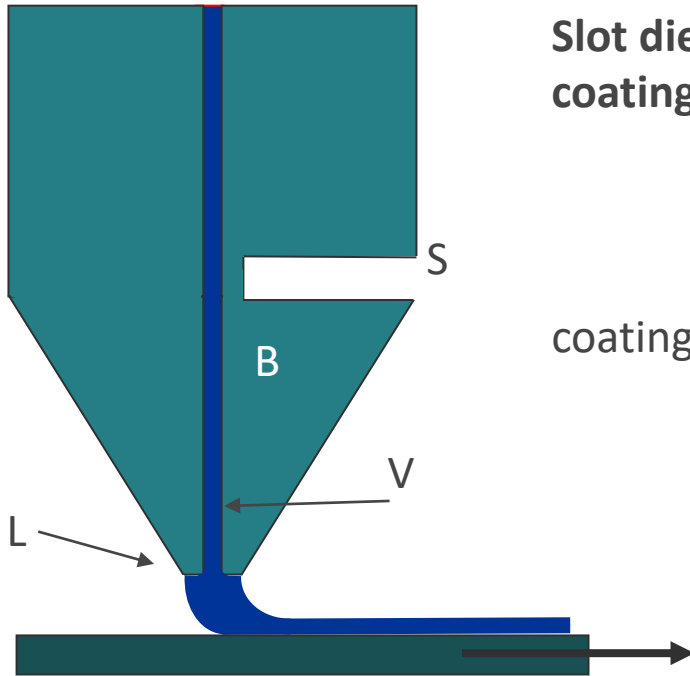

Slot die with movable lips:
coating mode

coating works as usual

- L lip
- V slot volume
- B bendable lip
- S bending slot

Structured coating – the switching slot die lip

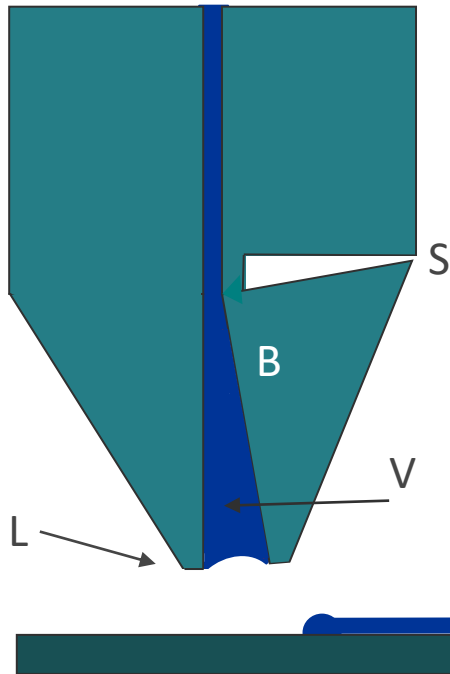

Slot die with movable lips:
stop mode

Bendable lip B flips open

Volume V increases and sucks
away the meniscus

- L lip
- V slot volume
- B bendable lip
- S bending slot

Technical implementation with bendable lips in action



5.

Digital application system





HELIOSONIC
PRINTING THE
UNPRINTABLE

HELIOSONIC PRINTING TECHNOLOGY
CREATES NEW POTENTIAL
FOR INDUSTRIAL DIGITAL PRINTING
AND SIGNIFICANTLY IMPROVES
THE USE OF RESOURCES.

Technology

Droplet Generation

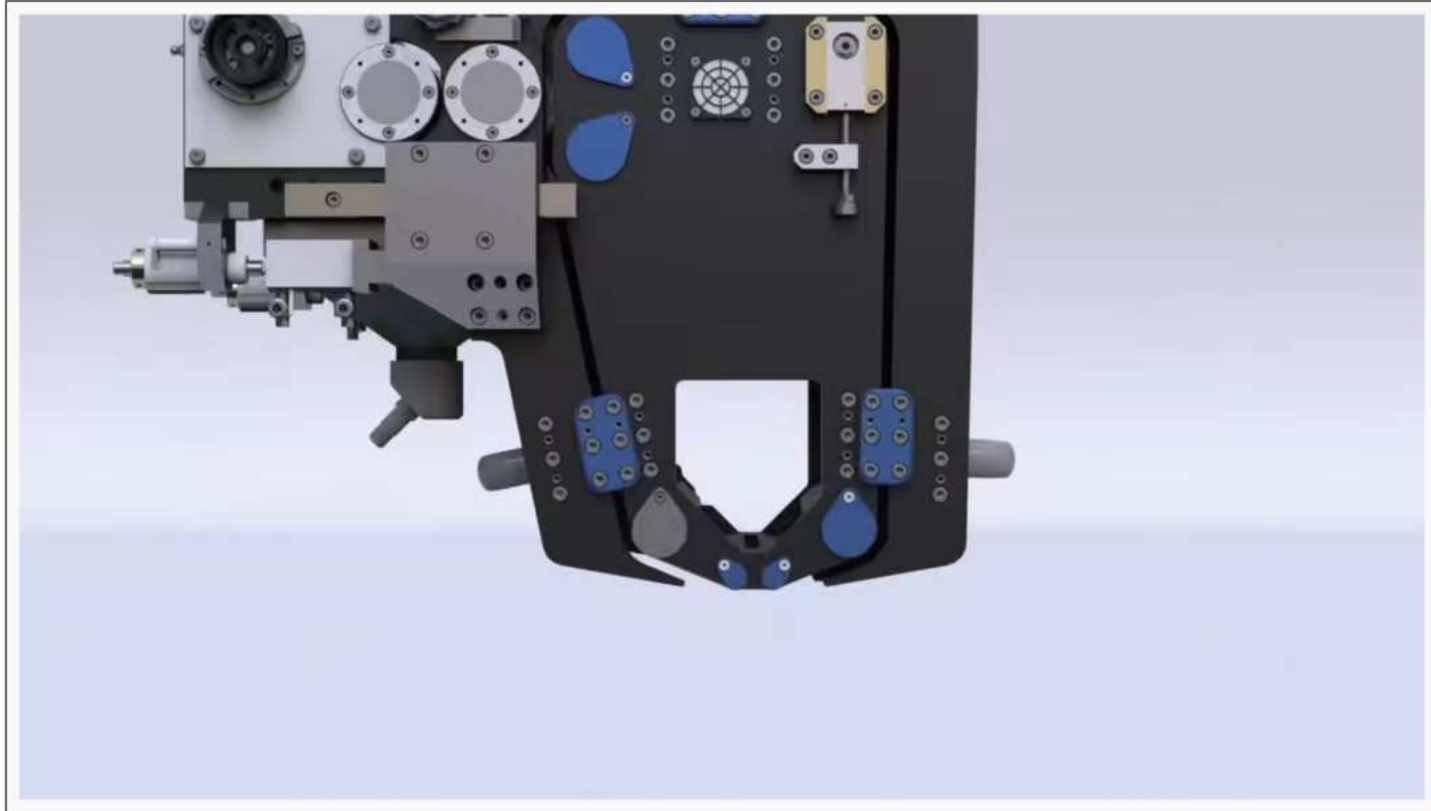

Technology

Inking & Printing



Value Proposition

Digitally deposited coatings

General

- Fully digital printing process without printing form
- Non-contact printing
- Multiple “wet-on-wet” printing
- Printing on sensitive substrates
- Tunable layer thickness 10-100µm
- Upper particle size limit ~ 100µm

Functional Inserts

- Sensors
 - Feature width 100µm+
 - Temperature
 - pH
 - Pressure and more
- Adhesives
- Sealants

Robustness

- Very robust and reliable process
 - No nozzle, slot or mesh clogging
 - Viscosity range of coatings/ inks from 10mPas to 1000mPas

Process Development Support

- Specific additives to make any ink HELIOSONIC compatible
- Broad know how based on optimized inks for complex designs
- Print parameter setting service

Precision

- Addressable 600dpi precision material deposition allows for:
 - Option for structured coatings with defined porosity/ channels
 - Sharp outlines
 - Non continuous coating (stop/ start) without reducing speed

Multi-material

- Combination of materials on dpi level; i.e.: -
 - Active/ inactive (inactive elements can be fillers or structural elements)
 - Conductive/ insulating

6.

Drying technologies



Introduction thermal drying – As general as possible(!?)

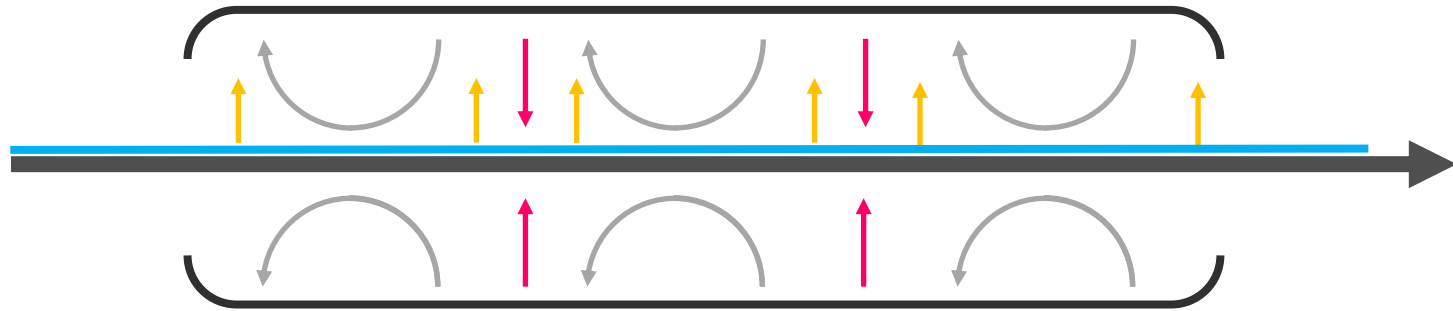

- ✓ Heat Conduction/ Heat Diffusion
- ✓ Heat Convection/ **Mass Transfer**
- ✓ Radiation



Substrate
Coating
Heat transfer
Evaporating solvent
Solvent vapor transfer



Mass Transfer

Basics mass + heat transfer – Drying dynamics: The Boundary Layer

An isolating air layer forms just on top of the coated film

- ✓ Without convection mass+heat transfer is limited to diffusion and therefore slow.
- ✓ Convective (laminar or turbulent) flow needs to be applied without sacrificing the coating surface.

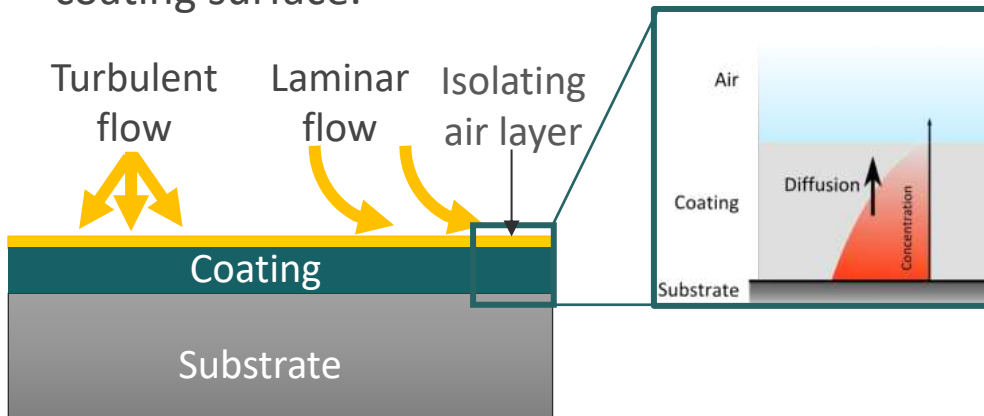

Usually there is a trade-off:

effective fast heat/mass transfer
or
gentle mild slow drying

Basics mass + heat transfer – Drying dynamics: Hot air drying

- ✓ Heating and vapor transport combined
- ✓ Bulk heating by thermal conductivity from surface
- ✓ Isolating layer to be overcome by air flow
- ✓ High air flow deteriorates surface
- ✓ Temperature easy to limit
- ✓ Slow

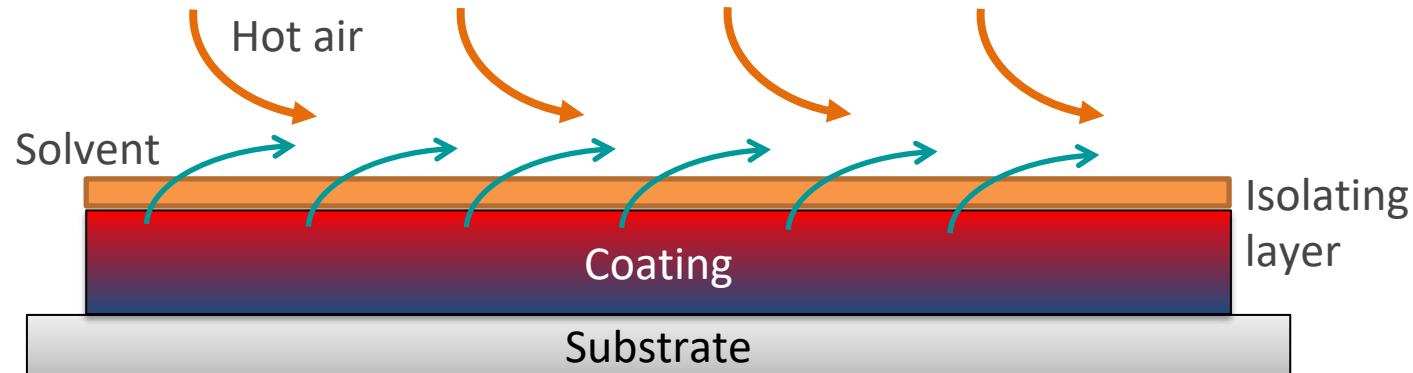

Basics mass + heat transfer

Nothing is as easy as it seems: Diffusion limit and skinning

- ✓ Drying is also limited by solvent diffusion (at least in the final state of low residual solvent content).
- ✓ If the internal diffusion is slower than the evaporation from the surface, then a skin may be created.
- ✓ The skin acts as a barrier. The remaining diffusion through the skin may be slower than the wet diffusion by many orders of magnitude.

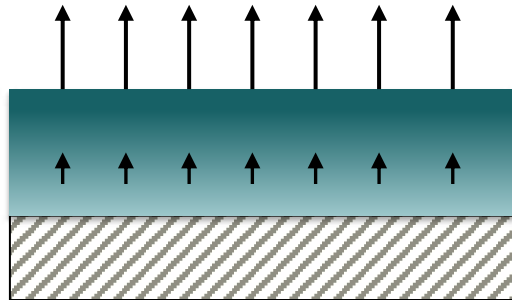

So the initial evaporation must be reduced by low temperature and/or by partially saturated atmosphere. Despite reduced evaporation the total drying time then may be shorter than at full initial evaporation.

Industrial drying systems

Coatema slot
nozle and
circulation
dryer on small
scale



Industrial drying systems

Coatema slot
nozle and
circulation
dryer on small
scale



Industrial drying systems

Coatema slot
nozle and
circulation
dryer on small
scale



Drytec Click&Coat™ dryer principle

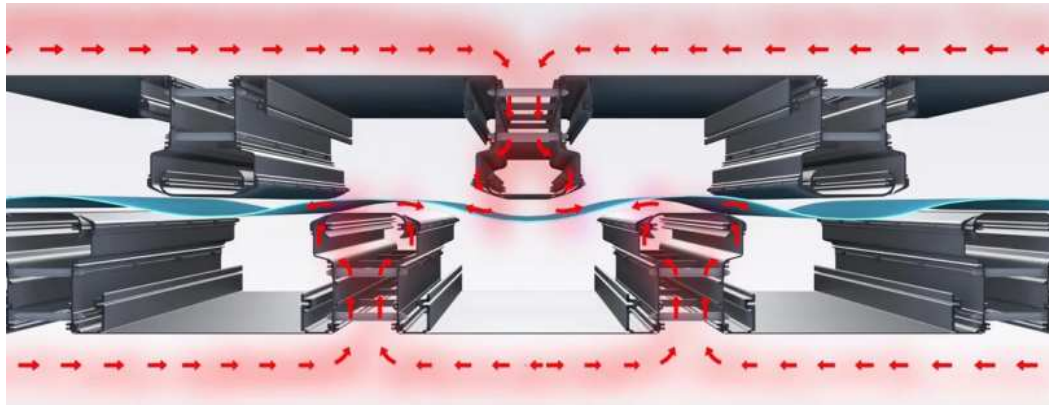

Drying topics – drying technologies: HighDry HD500

Web behaviour in a
flowtation dryer

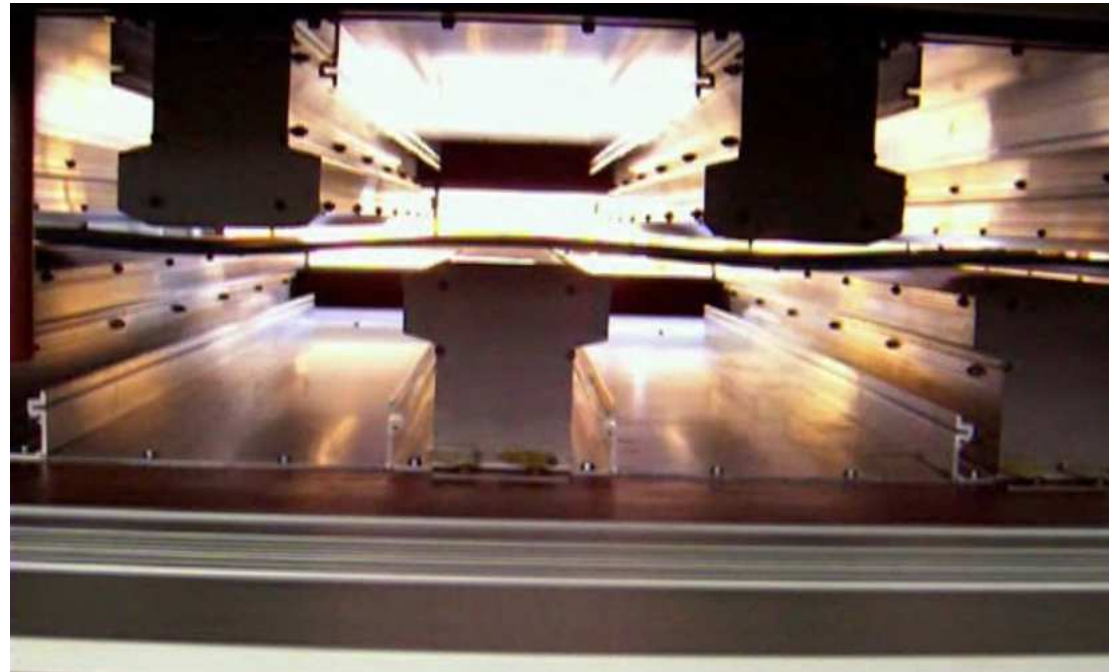

Press Button to
show the video

Basics mass + heat transfer: (N)IR technology

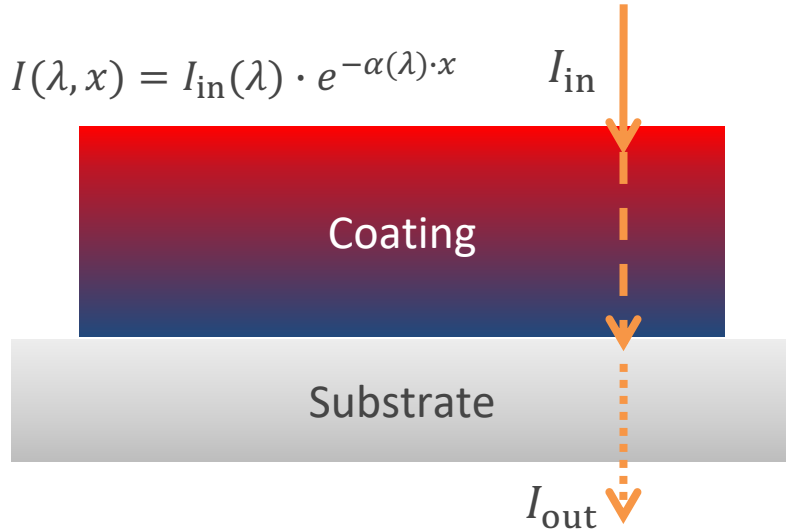

$I_{in}(\lambda)$ Intensity in
 I_{out} Intensity out
 $\alpha(\lambda)$ Absorption coefficient
 d Layer thickness

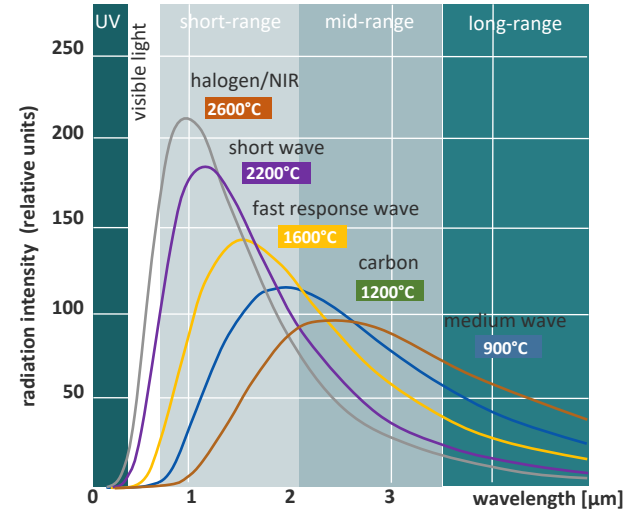
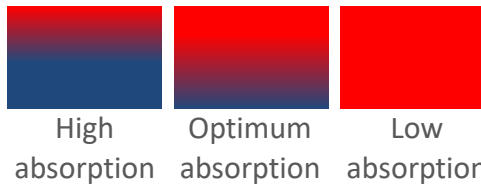

Relative intensity of radiators at different wavelengths

IR / NIR Drying – Infrared drying

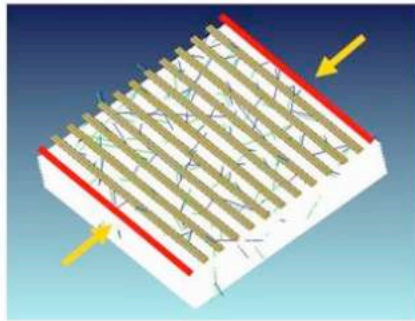

Continuous process

13 emitters, 2 types, 3 zones

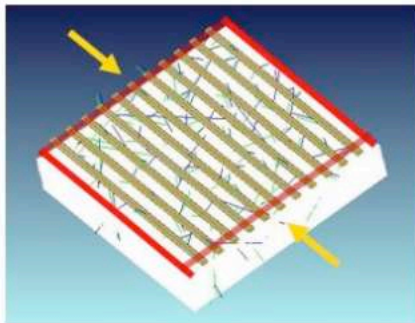
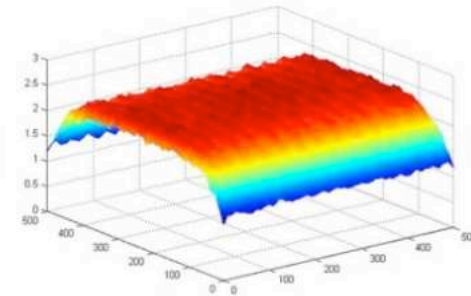

Batch process

15 emitters, 3 types, 5 zones

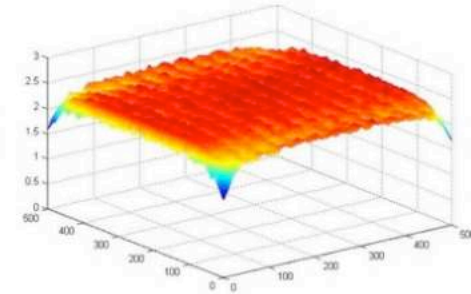

IR / NIR Drying – Infrared drying

Layout

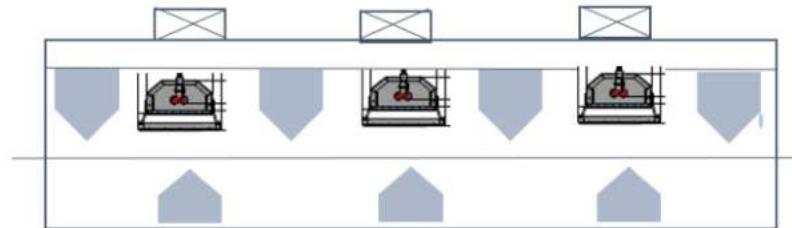
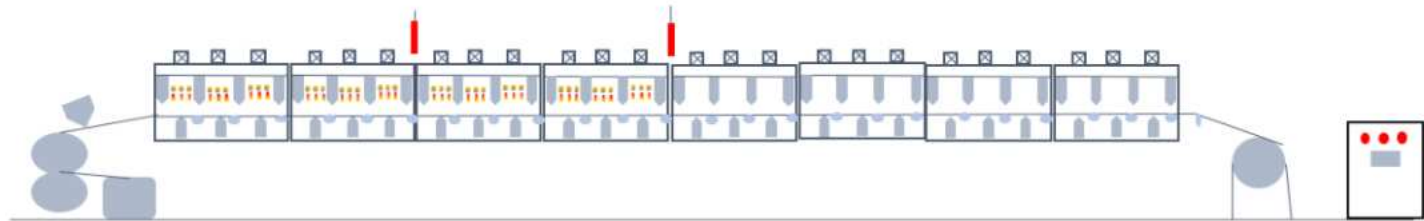

Hotair oven: 50m (10 zone)

IR at first 25m (5 zone) for boost

Heating distance : 100mm

Qty of IR : $60 * 3.1Kw = 186Kw$

7.

Simulation



Slot die chamber – Simulation parameters

- ✓ Example for anode coating
- ✓ Copper substrate
- ✓ Pseudo-Carreau Fluid match power law ($\mu_{inf}=1\text{mPas}$ time-constant =1 sec)
- ✓ Typical Coatema Slot die
- ✓ Process parameters for 90m/min 400 μm coating in 300 mm width

Name	Expression	Value	Description
W	0.8[mm]	8E-4 m	Slot gap
Hc	5[mm]	0.005 m	Inlet height
W_dd	1[mm]	0.001 m	Die width downstream
W_ud	1[mm]	0.001 m	Die width upstream
alpha_u	35[deg]	0.61087 rad	Upstream die angle
alpha_d	35[deg]	0.61087 rad	Downstream die angle
L_u	4.5[mm]	0.0045 m	Upstream length
L_d	10[mm]	0.01 m	Downstream length
H	0.7[mm]	7E-4 m	Coating gap
U_wall	90[m/min]	1.5 m/s	Coating velocity
m_power...	24.08	24.08	Estimated parameter m
gammadot	0.01	0.01	Shear rate optimization p...
n_powerL...	0.49	0.49	Estimated parameter n
Hcoat	0.4[mm]	4E-4 m	Coating Thickness
phi_die	25.9[deg]	0.45204 rad	Contact Angle Fluid-die
phi_sub	24[deg]	0.41888 rad	Contact Angle Fluid-Sub...
gamma_fl...	51.32[mN/m]	0.05132 N/m	Surface Tension Fluid

3D Homogeneity – Slot die chamber – Simulation of anode coating

- ✓ Example for anode electrode coating
- ✓ Fluid data taken from real world (shear-thinning power law fluid)
- ✓ Process parameters for 90m/min 400µm coating and 300 mm width
- ✓ No „fancy” slot-die „just” Coatema standard

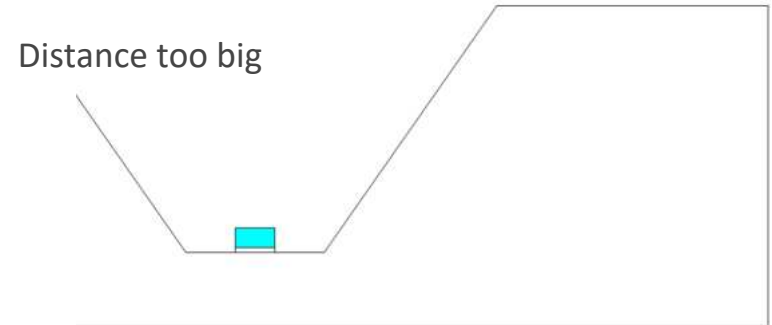
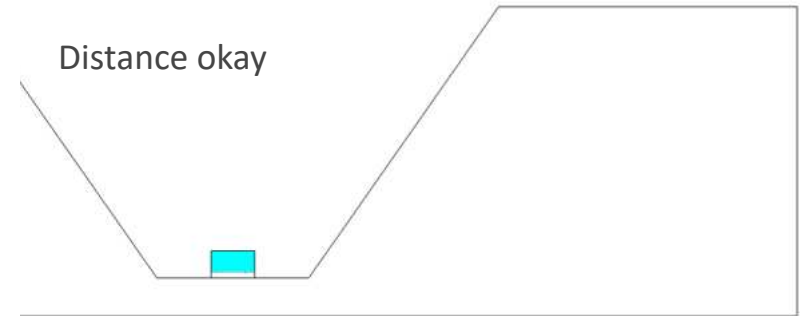

3D Homogeneity – Slot die chamber – Streamlines and pressure distribution

Single Chamber with too small inlet (4 mm)

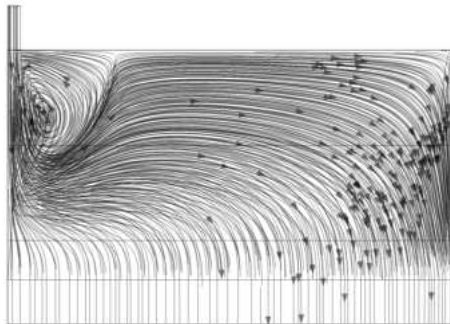
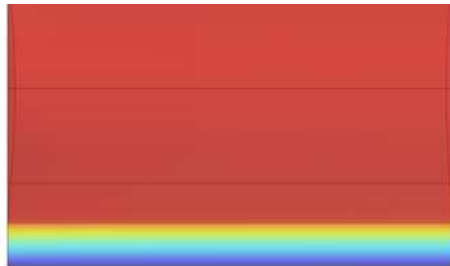

Single Chamber with correct chamber layout (10 mm inlet)

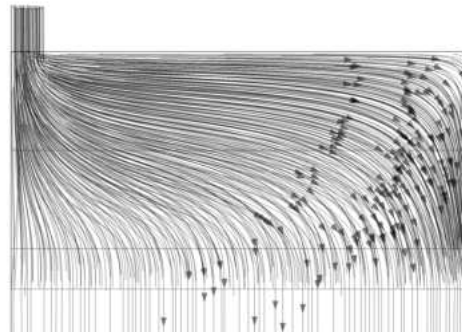
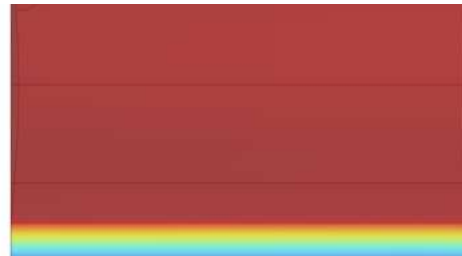

Dual chamber slot die (8 mm inlet same dead volume)

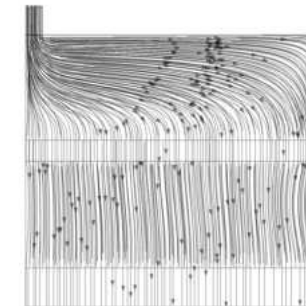
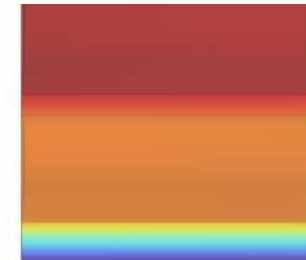

3D Homogeneity – Slot die chamber – Meniscus makes or breaks Homogeneity

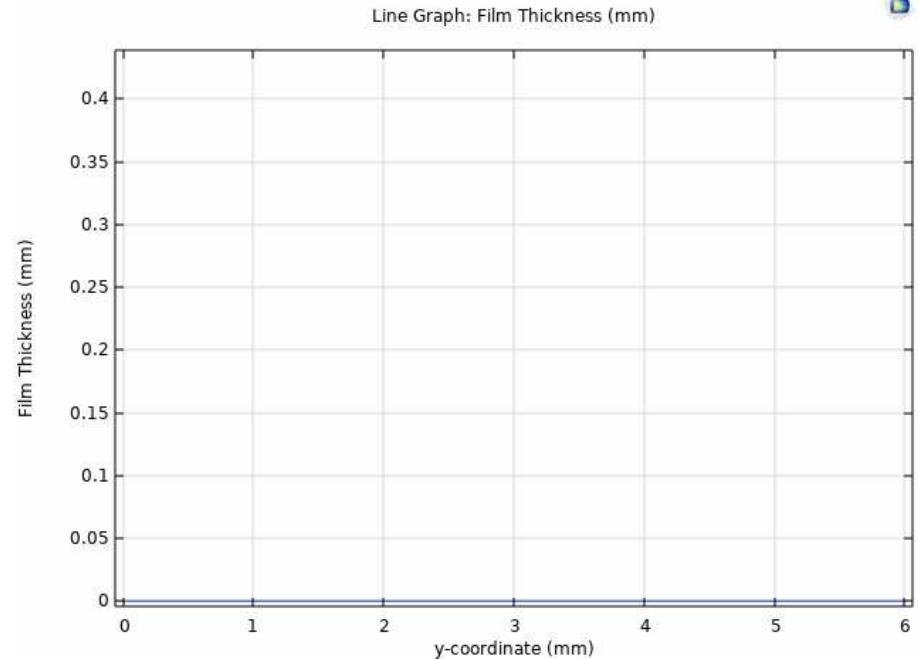
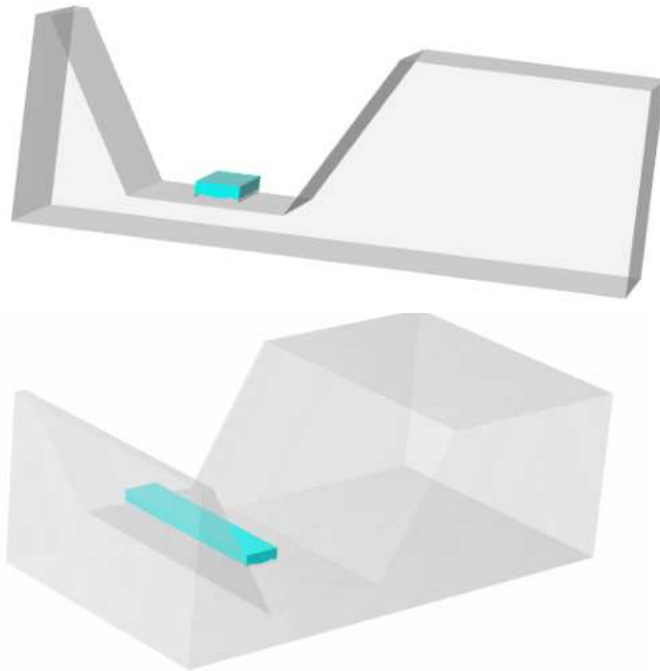

8.

Summary



Outlook

- ✓ Latest 2030 – 2050 the whole automotive car fleet has to be zero emission
- ✓ Impact markets will be automotive, light / heavy trucks, trains and decentralized power supply
- ✓ New green deal of the European Commission
- ✓ Markets will be PEMFC / HTPEMFC / SOFC / AFC / PEM Electrolyzer
- ✓ Coatema has over 22 years experience in the market of fuel cell equipment
- ✓ Electrolyzer to produce green hydrogen out of renewables will be the boom market in the next years to come and Coatema wants to be a part of it

Do not hesitate to contact us!



Anything missing?

Let us know and we will make it happen!

Our R&D centre is worldwide the most versatile centre for coating, printing and laminating.

Sales department:
sales@coatema.de

Download brochures & presentations



Coatema

Thank you

Roseller Straße 4 ▪ 41539 Dormagen ▪ Germany
T +49 21 33 97 84 - 0 ▪ info@coatema.de

www.coatema.com

MEMBER OF ATH